

X MIND prime



X-MIND prime User Manual

Contents

1. INTRODUCTION	1
1.1 Icons appearing in the manual	1
2. SPECIFICATION OF THE INTENDED USE	2
2.1 Application and medical purpose	2
2.1.1 Intended patient population	2
2.1.2 Operator Profile	2
2.1.3 Application environments	2
2.2 Applied parts	3
2.3 Typical doses delivered to the patient during extra-oral exams	4
3. SAFETY INFORMATION	6
3.1 Warnings	7
3.1.1 Precautions while using laser centring devices	8
3.2 Protection against radiation	9
3.2.1 Pediatric Use: Summary	10
3.3 Information about Electromagnetic Compatibility	11
3.3.1 Electromagnetic emissions	12
3.3.2 Electromagnetic immunity	13
3.4 Cybersecurity measures	14
3.5 Environmental risks and disposal	15
3.6 Symbols used	16
4. CLEANING AND DISINFECTION	18
5. DESCRIPTION	19
5.1 Identification labels and laser labels	19
5.1.1 Identification labels and laser labels	20
5.2 Functions, models and versions	21
6. TECHNICAL CHARACTERISTICS	22
6.1 Dimensions	28
6.2 Tube loading curves, anode heating and cooling curves	31
6.3 PC requirements	34
6.3.1 PC minimum characteristics	34
6.4 Software	35
6.5 X-MIND prime – PC communication	35
6.6 Reference standard	36
7. QUALITY ASSURANCE PROGRAM	38

7.1	Quality check tools	39
7.2	Functioning of the indicator lights	40
7.3	Laser alignment check	40
7.4	Image quality check	41
7.4.1	Geometry check	41
7.4.2	Signal to noise check	43
7.5	Dosimetry test (paragraph for authorised personnel)	45
7.6	LOG book	47
7.6.1	Image quality check	47
7.6.2	Verification of radiological parameters	48
8.	GENERAL INSTRUCTIONS FOR USE	49
8.1	Switching the device ON and OFF	49
8.1.1	Emergency button	49
8.2	Positioning the chin support	50
8.3	Keyboard - Description and functions	51
8.4	Graphical User Interface - Description and functions	53
8.4.1	Main GUI area functions	55
8.5	Digital sensor	56
8.6	Making an exam	57
8.7	Anatomic / Manual exposure	58
8.7.1	Anatomic exposure	59
8.7.2	Manual exposure	59
8.8	Panoramic and Bitewing exams	60
8.8.1	Laser references	60
8.8.2	Preparation of the device	61
8.8.3	Preparation of the patient	68
8.8.4	Taking an exposure	71
8.8.5	Image processing windows	74
8.9	Sinus exam	77
8.9.1	Preparation of the patient	79
8.9.2	Taking an exposure	81
8.10	TMJ exam	83
8.10.1	Preparation of the device	85
8.10.2	TMJ closed mouth: preparation of the patient	88
8.10.3	Carrying out the first exposure	90
8.10.4	TMJ open mouth: preparation of the patient	92
8.10.5	Carrying out the second exposure	94
8.11	Table of pre-set anatomic parameters	95
9.	ERROR MESSAGES	96

10. MAINTENANCE	99
11. PANORAMIC IMAGE ASSESSMENT	101
11.1 Proper positioning of the patient	102
11.2 Patient positioning errors	104
11.2.1 Turned head	104
11.2.2 Tilted head	105
11.2.3 Downward angulation of the head	106
11.2.4 Backward angulation of the head	107
11.2.5 Tongue effect	108
11.2.6 Spine effect	109

**Note**

No part of this publication can be reproduced, transmitted, transcribed or translated without the approval of ACTEON.

This manual in English is the original Manual version.



THIS PAGE IS INTENTIONALLY LEFT BLANK

1. INTRODUCTION

Note



This manual is updated for the product it is sold with, to guarantee an adequate reference for using the product properly and safely. The manual may not reflect changes made to the product that do not affect operating procedures or safety.

X-MIND prime, manufactured by de Götzen, is an X-ray device for the radiographic analysis of the maxillo-facial complex.

X-MIND prime performs Panoramic, Half-panoramic, Low dose Panoramic, Frontal dentition, Ortho Rad Panoramic, Bitewing Bilateral, Bitewing Left and Bitewing Right, Sinus and TMJ of the maxillo-facial complex.

The aim of this Manual is to instruct the user on the safe and effective use of the device. The device must be used complying with the procedures described in this Manual and never be used for purposes other than those indicated herein.

Please read this Manual thoroughly before starting to use the unit; it is advisable to keep the manual close to the device, for reference while operating.

X-MIND prime is an electrical medical device and can only be used under the supervision of a physician or of highly qualified personnel, with necessary knowledge of X-ray protection. The user is liable for legal compliance in relation to the installation and operation of the device.

1.1 Icons appearing in the manual



This icon indicates a “NOTE”: please read the items marked by this icon thoroughly.



This icon indicates a “WARNING”: the items marked by this icon refer to safety aspects of the patient and/or operator.

2. SPECIFICATION OF THE INTENDED USE

2.1 Application and medical purpose

X-MIND prime is an extra-oral dental panoramic X-ray unit to radiograph teeth, jaw and oral structures.

The device is operated and used by dentists, radiologists and other legally qualified health care professionals. It can be used with both paediatric and adult patients.

Caution

Federal law restricts this device to sale by or on the order of a dentist, a radiologist or another legally qualified health care professional.

2.1.1 Intended patient population

X-MIND prime system can be used with the following type of patient:

- Age: paediatric (from about 7 years) to geriatric
- Patient status:
 - self-sufficient patient (the patient can autonomously place himself as requested by the physician)
 - non self-sufficient patient (the patient is assisted by medical personnel).
 - In any case the patient must be conscious, not anaesthetized and not incapacitated
- Nationality: multiple.

2.1.2 Operator Profile

This system may only be operated by persons who have suitable experience in radiation protection or knowledge of radiation protection and who have been instructed in the operation of the X-ray equipment.

2.1.3 Application environments

X-MIND prime may be used in professional buildings (e.g. hospitals, private clinics) or in residential buildings. For the purpose of EMC environment classification both installations are classified as "Professional healthcare facility environment".



Note

In the radiographic room, direct audio and visual communication between operator and patient shall be always possible. Otherwise, provide proper support (i.e. lead glass or similar, interphone, etc.).



2.2 Applied parts

During normal use, X-MIND prime is in contact with the patient via the handle, the chin rest and bite and the temple clamp, classified as Type B applied parts.

2.3 Typical doses delivered to the patient during extra-oral exams

The air kerma at the entrance of the X-ray image receptor for the standard PANORAMIC exam is:

mA	2	2.2	2.5	2.8	3.2	3.6	4	4.5	5	5.6	6.3	7.1
kV	Air Kerma [mGy]											
60	2.54	2.79	3.17	3.55	4.06	4.56	5.07	5.70	6.34	7.10	7.99	9.00
62	2.65	2.91	3.31	3.71	4.24	4.77	5.30	5.96	6.62	7.41	8.34	9.40
64	2.87	3.16	3.59	4.02	4.60	5.17	5.75	6.46	7.18	8.05	9.05	10.20
66	3.10	3.41	3.87	4.34	4.96	5.58	6.20	6.97	7.75	8.68	9.76	11.00
68	3.24	3.56	4.05	4.54	5.18	5.83	6.48	7.29	8.10	9.07	10.20	11.50
70	3.52	3.89	4.40	4.93	5.63	6.34	7.04	7.92	8.80	9.86	11.10	12.50

The air kerma for the other exams available on the equipment can be calculated using the ratios in the table below:

Exam	Ratio
Half-panoramic	0.55
Low Dose	0.85
Ortho Rad panoramic	0.90
Frontal dentition	0.33
Bitewing L or R	0.24
Bitewing L and R	0.47
TMJ	0.71
Sinus	0.65

The dose per area of products delivered by X-MIND prime to the patient during extra-oral exams is indicated in the graphical user interface.



Note

The dosimetric indications result from the average of dose measures on a lot of X-rays source assemblies.

The dose is taken at a certain distance from the focal spot of the X-ray source and then reported to the imaging plane.

To get the DAP value, the dose on the imaging plane is multiplied by the X-ray field area measured on the imaging sensor that is 50 cm far away from focal spot (the typical size of the X-ray beam on the imaging sensor is 140 mm x 4.5 mm).

The distance between the focal spot and the patient skin is variable during the X-ray and on average we can assume the mean distance between the focal spot and the patient skin as 264 mm.

The overall uncertainty of the indicated value of the air Kerma and dose per area product is 50%.



Note

As stated in IEC 60601-2-63, no deterministic effects are known with extra-oral dental X-ray equipment.

3. SAFETY INFORMATION

**Warning**

Please read this chapter thoroughly.

Devices are designed and manufactured in compliance with safety requirements; furthermore it supplies all information necessary for correct use, and warnings related to dangers associated with X-ray generating units.

Acteon cannot be held liable for:

- Use of X-MIND prime other than its intended use
- Damage to the unit, the operator or the patient, caused both by installation and maintenance procedures other than those described in this Manual and in the Service Manual supplied with the unit, and by erroneous operations
- Mechanical and/or electrical modifications performed during and after the installation, other than those described in the Service Manual.

Installation and any technical operations must only be performed by qualified technicians authorised by Acteon.

Only authorised personnel may remove the covers and/or have access to live components.

The responsibility for the quality assurance program is defined in chapter 7.

Acteon provides specific training for service engineers.

Acteon technical support sends to all authorized dealer training course calendar.

One copy of User and Service Manual are always provided with the unit.

**Warning**

In compliance with the IEC 60601-1 standard, the modification of the equipment or its parts is strictly prohibited.

3.1 Warnings

The device must be used in compliance with the procedures described and never be used for purposes other than those indicated herein.

Before performing any maintenance operation, disconnect the unit from the power supply.

X-MIND prime is an electric medical device and so can only be used under the supervision of suitably qualified medical personnel, with necessary knowledge of X-ray protection.

The user is responsible for compliance with legal requirements as regards ownership, installation and use of the equipment.

The user is responsible for a safe set-up and maintenance of the host PC; as a general guidance cybersecurity suggestions are given in paragraph 3.4 of this Manual.

The user is responsible for the execution of the routine quality control procedure described in chapter 7 of this Manual.

This device has not been designed for use in environments where vapours, anaesthetic mixtures flammable with air, or oxygen and nitrous oxide, may be present.

Do not let water, or other liquids, penetrate the device, as this could cause short circuits and corrosion.

Before cleaning the device, make sure the main power supply has been disconnected from the equipment. When pushing the ON/OFF button of the equipment, it must not come on.

Wherever necessary, use appropriate accessories, such as leaded aprons, to protect the patient from radiation.

While performing the X-ray, no-one, apart from the operator and the patient, must remain in the room.

X-MIND prime has been built for continuous operation with an intermittent load; so the described use cycles must be observed, to enable the device to cool down.

X-MIND prime must be switched off while using electrosurgical devices or similar apparatus.



Warning

For safety reasons, the patient support arm must not be abnormally overloaded, for example by leaning on it. The traction on the handle must be less than 16 kg.



Warning

To avoid the risk of electric shock, the equipment must only be connected to a mains supply with earthing.

Clean and disinfect, when necessary, all parts that may come into contact with the patient.

The centring bite or the bite protective sleeve must be replaced after each exam.

To avoid permanent damage to the unit, never try to rotate the moving arm manually when the unit is switched on.

In the case of Error 362 or Error 760, movement is possible to let the patient exit.



Note

When the unit is switched on, do not move the rotating arm.

3.1.1 Precautions while using laser centring devices

For patient positioning, X-MIND prime uses two laser diodes with optical power on the working surface < 1 mW.

The directive CEI-EN 60825-1 defines the laser as "any device that produces or amplifies electromagnetic radiation in a coherent manner which includes a wave lengths from 180 nm to 1 mm by means of a stimulated emission". In reference to this directive, the lasers present on the X-MIND prime are parts of class 2.

A laser in class 2 can be potentially dangerous if the ray is reflected into not protected eyes by a mirror, watch, a ring etc.

The warning label below is affixed to X-MIND prime to indicate a laser in class 2 is mounted internally and caution is advised:

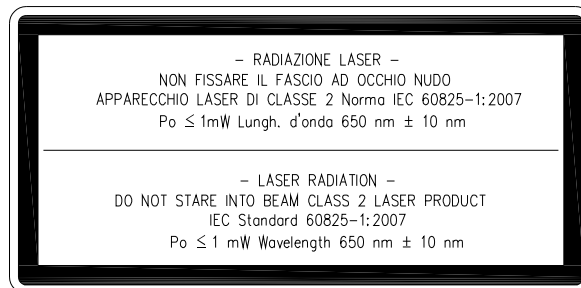

Warning

- Always keep the room well lit.
- Do not look into the output windows of laser centring units.
- Do not stare at the reflections of laser pointers.
- Instruct the patient to keep his/her eyes closed as long as the laser pointers are active.
- Before starting an exam, the patient must remove earrings, glasses, necklaces and any other item that could reflect the laser beam or be impressed on the radiographic image.
- Do not clean the openings of laser centring devices with tools that could modify the optics. Any cleaning must only be performed by authorized technicians.
- Operations other than those indicated could cause the emission of dangerous non-ionizing radiation.

3.2 Protection against radiation

Although the dose supplied by dental X-ray units is quite low and distributed on a fairly small surface, the operator must adopt precautions and/or suitable protection for the patient and himself, during radiography.



Warning

Protection against radiation is regulated according to law.
The equipment may only be used by specialised personnel.

It is advisable to control the X-ray emission from a protected area, by remote control. If it is necessary to operate near the patient, stay as far as the remote control cable allows, or at least 2 m both from the X-ray source and from the patient, as shown in the following figure.

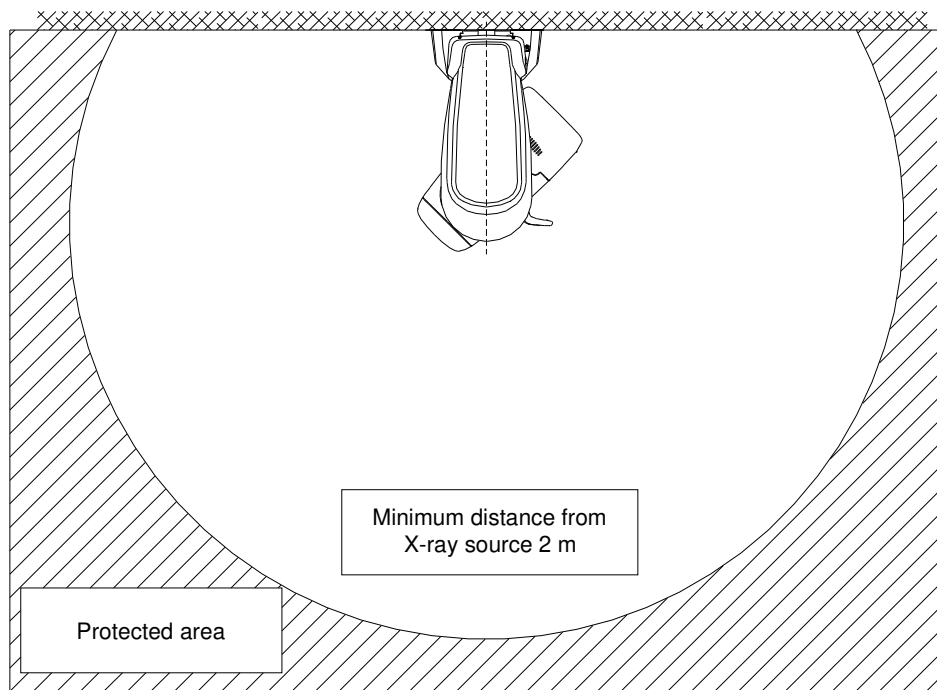

Figure 1

3.2.1 Pediatric Use: Summary

3.2.1.1 Introduction

Special care should be exercised when imaging patients outside the typical adult size range, especially smaller pediatric patients whose size does not overlap the adult size range (e.g., patients less than 50kg (110lb) in weight and 150cm (59") in height, measurements, which approximately correspond to that of an average 12 years old or a 5th percentile U.S. adult female).

3.2.1.2 References for pediatric dose optimization

The following resources provide information about pediatric imaging radiation safety and/or radiation safety for extra-oral dental panoramic and CBCT (aka CBVT) X-ray devices:

1. [HTTPS://WWW.FDA.GOV/RADIATION-EMITTINGPRODUCTS/RADIATIONEMITTINGPRODUCTSANDPROCEDURES/MEDICALIMAGING/UCM298899.HTM](https://www.fda.gov/radiation-emitting-products/radiation-emitting-products-and-procedures/medical-imaging/ucm298899.htm)
2. www.imagegently.org
3. [HTTPS://WWW.FDA.GOV/RADIATION-EMITTINGPRODUCTS/RADIATIONEMITTINGPRODUCTSANDPROCEDURES/MEDICALIMAGING/MEDICALX-RAYS/UCM315011.HTM](https://www.fda.gov/radiation-emitting-products/radiation-emitting-products-and-procedures/medical-imaging/medical-x-rays/ucm315011.htm)
4. <https://www.iaea.org/resources/rpop/resources/training-material#11>
5. [HTTPS://WWW.IAEA.ORG/RESOURCES/RPOP/RESOURCES/TRAINING-MATERIAL#3](https://www.iaea.org/resources/rpop/resources/training-material#3)

3.2.1.3 Device specific features and instructions

X-MIND prime provides as standard with all units, the following specific design features and instructions that enable safer use of our device with pediatric patients:

Design features important to paediatric imaging	Paragraph
Adult/Child exam modality: child selection adapts exposure current (mA) and High voltage (kV) reducing the overall dose supplied to the patient.	8.4 and 8.11
For the panoramic exams (panoramic, half-panoramic and low dose panoramic programs) Child selection also corresponds to a reduced trajectory exam time giving a further 10% of dose reduction.	8.11
A function to run the exam in test mode without X-ray to check the behaviour of the patient during the exam and reduce the possibility of exam interruption and retake	8.6 and 8.8.3

3.3 Information about Electromagnetic Compatibility

Medical electrical equipment needs special precautions regarding EMC and needs to be installed and put into service according to the EMC information provided in the accompanying documents.

Portable and mobile RF communications equipment can affect medical electrical equipment.

The equipment can be installed both in professional buildings (e.g. hospitals or clinics) and in residential buildings. Residential buildings, according to IEC 60601-1-2 4th edition, are intended to be connected to dedicated power supply system (normally fed by separation transformers).

For the purpose of EMC environment classification according to IEC 60601-1-2 4th edition, both installations are classified as "Professional healthcare facility environment".

The EMISSIONS characteristics of this equipment make it suitable for use in industrial areas and hospitals (CISPR 11 class A). If it is used in a residential environment (for which CISPR 11 class B is normally required) this equipment, even if it is usually permanently installed in X-Ray shield locations, might not offer adequate protection to radio-frequency communication services. If abnormal performance is observed, such as degradation of essential performance in the form of lack of accuracy of exposure parameters and lack of reproducibility of exposure parameter, additional measures may be necessary, such as re-orienting or relocating the device.



Warning

The use of cables other than:

- Ethernet cable CAT.5E L=5 m - code 5007090100
- Ethernet cable CAT.5E L=10 m - code 5007090300

with the exception those sold by the manufacturer of the equipment or system as replacement parts for internal components, may result in increased emission or decreased immunity of the equipment or system.



Warning

X-MIND prime should not be used adjacent to or stacked with other equipment; if adjacent use is necessary, X-MIND prime has to be observed to verify if it operates in a normal way.

Interference may occur in the vicinity of equipment marked with the symbol



Warning

Portable and mobile RF communications equipment should be used no closer to any part of X-MIND prime, including cables. Minimum distance 30 cm.

3.3.1 Electromagnetic emissions

In accordance with the IEC 60601-1-2 Ed4 standard, X-MIND prime is suitable for use in the electromagnetic environment specified below.

The customer or user of the system must ensure that it is used in the said environment.

Emissions test	Compliance	Electromagnetic environment
RF emissions CISPR 11	Group I	X-MIND prime uses RF energy only for its internal function. Therefore, its R.F. emissions are very low and are not likely to cause any interference in nearby electronic equipment.
	Class A	X-MIND prime is suitable for use in all establishments other than domestic and those directly connected to the public low voltage power supply network that supplies buildings used for domestic purposes.
Harmonics emissions IEC 61000-3-2	Class A	
Voltage fluctuations/ flicker emissions IEC 61000-3-3	Complies	

3.3.2 Electromagnetic immunity

In accordance with the IEC 60601-1-2 Ed4 standard, X-MIND prime is suitable for use in the electromagnetic environment specified below.

The customer or user of the system must ensure that it is used in the said environment.

Immunity test	IEC 60601-1-2 test level	Compliance level	Electromagnetic environment
Electrostatic discharge (ESD) IEC 61000-4-2	8 kV contact 2/4/8/15 kV air	IEC 60601-1-2 Test level	Floors should be wood, concrete or ceramic tile. If floors are covered with synthetic material, the relative humidity should be at least 30%
Radiated electromagnetic field IEC 61000-4-3	3 V/m 80 MHz to 2.7 GHz	IEC 60601-1-2 Test level	Portable and mobile RF communications equipment should be used no closer to any part of X-MIND prime including cables. Minimum distance 30 cm
Electrical fast transient/burst IEC 61000-4-4	2 kV for power supply lines 1 kV for input/output lines > 3 m	IEC 60601-1-2 Test level	Mains power quality should be that of a typical commercial or hospital environment
Surge IEC 61000-4-5	0.5/1 kV differential mode 0.5/1/2 kV common mode	IEC 60601-1-2 Test level	Mains power quality should be that of a typical commercial or hospital environment
Conducted disturbances induced by RF fields IEC 61000-4-6	3 V 150 kHz to 80 MHz 6 V ISM frequencies	IEC 60601-1-2 Test level	Portable and mobile RF communications equipment should be used no closer to any part of X-MIND prime, including cables. Minimum distance 30 cm
Voltage dips, short interruptions and voltage variations on power supply input lines IEC 61000-4-11	10 ms – 0% a 0°, 45°, 90°, 135°, 180°, 225°, 270°, 315° 20 ms – 0% a 0° 500 ms – 70% a 0° 5 s – 0%	IEC 60601-1-2 Test level	Mains power quality should be that of a typical commercial or hospital environment. If the user of the EUT requires continued operation during power mains interruptions, it is recommended that the EUT be powered from an uninterruptible power supply or a battery
Power frequency (50/60 Hz) magnetic field IEC 61000-4-8	30 A/m	IEC 60601-1-2 Test level	Power frequency magnetic fields should be at levels characteristics of a typical location in a typical commercial or hospital environment

3.4 Cybersecurity measures

Like all computer-based systems, X-MIND prime might be exposed to Cybersecurity threats.

X-MIND prime is equipped with hardware provisions that make sure that no unwanted X-ray exposure, laser radiation or motorized movements can be activated even in case of cyber-attack or software failure.

Nevertheless, in order to minimize the possibility of cyber-attacks, it is the user responsibility to make sure that the following protection measures are followed.

- The initial software installation and system set-up shall be done by authorized and trained personnel only and using the software provided with the machine
- Any software or firmware upgrade of the equipment shall be done by authorized and trained personnel only
- After any software or firmware upgrade, or any other maintenance operation, image quality checks shall be performed to ensure the system is working as expected. Instructions are given in chapter 7
- Password-protect each user account on the Windows login. Passwords shall be strong enough (at least made of 8 alphanumeric characters), shall be safely managed by every user (for example they have not been written down), and should be periodically changed (if the system is supplied with a PC, the Windows user is password-protected, but it is user responsibility to change the default password and set new ones for all the different users that will have access to the system)
- Activate a screensaver that requires a password to be unblocked after a timeout of 5-10 minute, giving this way an automatic timed method to terminate sessions, preventing an unauthorized access to the computer when it is not used (if the system is supplied with a PC, the screen saver is activated by default)
- Install an antivirus software and keep virus definitions up to date
- Activate the windows firewall on the host PC (if the system is supplied with a PC, the Windows firewall is activated by default)
- It is recommended to activate a hardware firewall on the WAN router/modem used for internet connection, if present
- Make sure that all other PCs in the network are protected by an anti-virus
- Make a virus scan of USB sticks or CD/DVD media before using them to check that they are free of viruses, malware or any dangerous software
- Avoid installation of an unknown or untrusted software since it may undermine the performance and safety of the computer and the equipment
- Keep the Windows operating system up to date by installing all security patches
- Make regular copies (backup) of all your valuable data and store them in a safe place, separately from the host PC

3.5 Environmental risks and disposal

Some parts of the device contain materials and liquids that, at the end of the unit's lifecycle, must be disposed of at appropriate disposal centres.

In particular, the device contains the following materials and/or components:

- Tube-head: dielectric oil, copper, iron, aluminium, glass, tungsten, lead.
- Collimator: lead
- Other parts of the device: non-biodegradable plastic materials, metal materials, printed circuits, iron-plastic materials, lead.



Note

Information for users of the European Community according to 2011/65/EU Directive on the restriction of the use of certain hazardous substances in electrical and electronic equipment.



The symbol of the crossed waste container on the equipment or packaging shows that the product, at the end of its lifecycle, must be collected separately from other types of waste.













The separate collection of this equipment at the end of its lifecycle is organised and managed by the manufacturer. Users who need to dispose of this equipment should therefore contact the manufacturer and follow the procedure adopted by the manufacturer for the separate collection of the equipment at the end of its lifecycle.







Proper separate collection for subsequent recycling, treatment and compatible environmental disposal of equipment helps avoid possible negative effects on the environment and on health and encourages the reuse or recycling of materials the equipment is made from.

Illegal disposal of the product by the owner of the equipment will result in administrative sanctions, as provided for by applicable regulations.

3.6 Symbols used

In this manual and on X-MIND prime itself, apart from the symbols indicated on the keyboard, the following icons are also used:

Symbols	Description
	Device with type B applied parts
	Some parts of the device contain materials and liquids that, at the end of the unit's lifecycle, must be disposed of at appropriate disposal centres.
~	A.C. voltage
N	Connection point to the neutral conductor
L	Connection point to the line conductor
	Protection grounding
	Functional grounding
○	OFF; device not connected to the mains
	ON; device connected to the mains
	Laser
	Dangerous voltage
	Product identification code
	Serial number
	Manufacturing date (year and month)
	Name and address of the manufacturer
	Filtration
	Tube-head
	X-Ray tube

Symbols	Description
	Focal spot according to IEC 60336
	Follow instructions for use
	Conformity to the Directive 93/42/EEC and its revised version and all other applicable Directives
	Exposure enabled status (the corresponding green LED is on)
	X-Ray emission (the corresponding yellow LED is on)
	Electronic instructions for use symbol for medical devices, according to EN ISO 15223-1: 2016

4. CLEANING AND DISINFECTION

In order to guarantee a good level of hygiene and cleaning, it is necessary to carry out the following procedures.

**Warning**

Disconnect the unit from the mains before performing any cleaning.

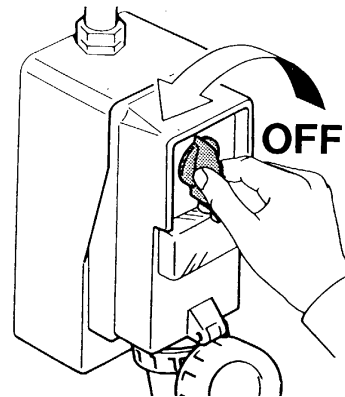

Do not let water or other liquids penetrate the unit, as these could cause corrosion or short circuits.

Use only a wet cloth and a mild detergent to clean the painted surfaces, accessories and connection cables and then wipe with a dry cloth; do not use corrosive, abrasive solvents (alcohol, benzene, trichloroethylene).

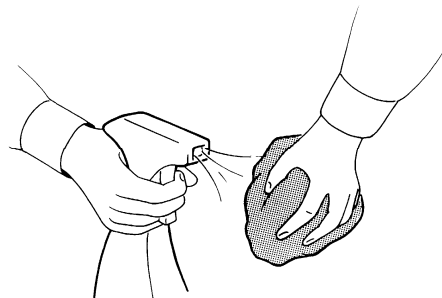

The centring bite or the bite protective sleeve must be replaced after each exam. Thoroughly clean the chin support, resting handles and temple clamps group whenever they are used.

The chin support, resting handles and temple clamps group should be disinfected (when considered necessary) with a solution of 2% glutaraldehyde.

**Note**

To ensure a greater level of hygiene the handles of the equipment are covered with a special antibacterial paint which, thanks to the emission of silver ions, prevents the development of micro-organisms.

5. DESCRIPTION

5.1 Identification labels and laser labels

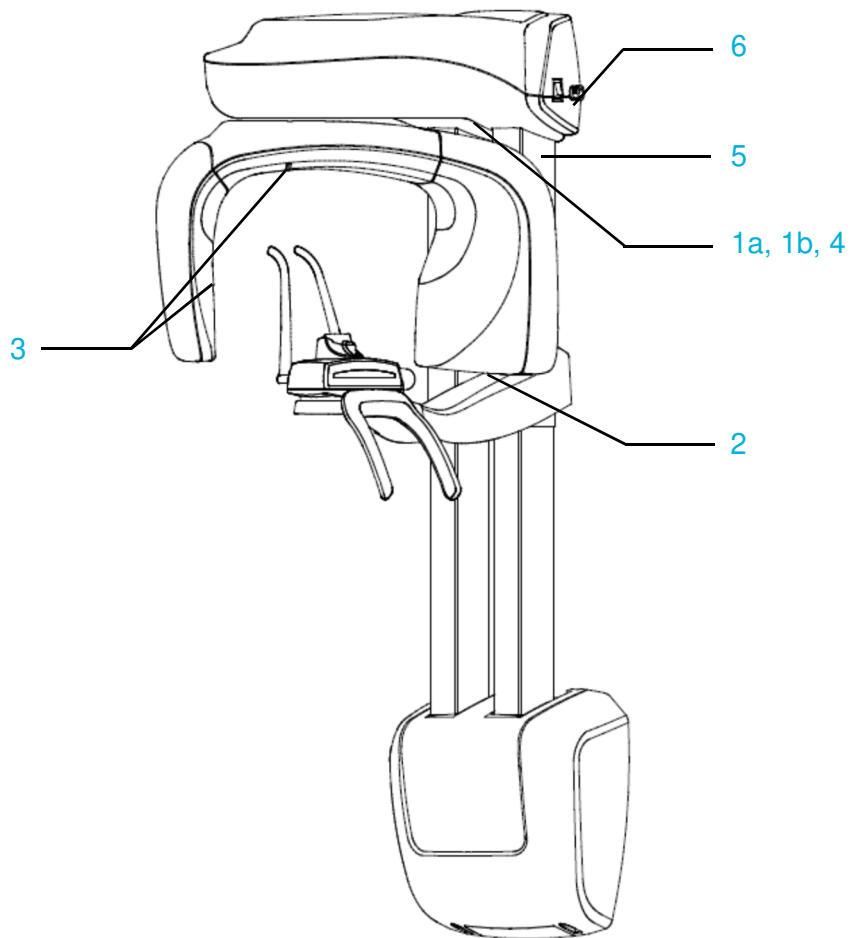

Figure 2: Identification labels

5.1.1 Identification labels and laser labels

1a
X-MIND prime
identification label

X-MIND prime		REF W1200001
XMP 2D WALL 110-240V		
	Line: 110-240 V~, 7-3.5 A ; 50/60 Hz	
	SN	
	de Götzen srl Via Roma 45 21057 OLGIATE OLONA (VA) - Italy	
www.acteongroup.com		
	This product complies with FDA radiation performance standards 21 CFR subchapter J, in effect at date of manufacture	

1b
UDI label

Model: X-MIND prime	Ref:
REF	SN
UDI CODE	
+D804W12000010I	
+\$\$+7YYMMXXXX/16D20190924I0	

2
Tube-head
identification label

	MPV05	REF 8404000100	SN YYMMNNNN
Output max: 70 kVp - 7.1 mA			YYYY-MM
Duty cycle: 1/16		Max exposure time: 14.4 s	
	IEC60522		
	de Götzen S.r.l. Via Roma 45 21057 Olgiate Olona (VA) – ITALY		
	SN NNNNNN	0.5 IEC60336	

3
(No. 2) Laser symbol label



4
Laser WARNING label

<p>– RADIAZIONE LASER – NON FISSARE IL FASCIO AD OCCHIO NUDO APPARECCHIO LASER DI CLASSE 2 Norma IEC 60825-1:2007 Po ≤ 1mW Lunghezza d'onda 650 nm ± 10 nm</p>
<p>– LASER RADIATION – DO NOT STARE INTO BEAM CLASS 2 LASER PRODUCT IEC Standard 60825-1:2007 Po ≤ 1 mW Wavelength 650 nm ± 10 nm</p>

5
WARNING label

COMPLIES WITH DHHS PERFORMANCE STANDARD 2 - CFR SUBCHAPTER J

WARNING:
THIS X RAY UNIT MAY BE DANGEROUS TO THE PATIENT AND OPERATOR UNLESS SAFE EXPOSURE FACTORS AND OPERATING INSTRUCTIONS ARE OBSERVED.
ELECTRICAL SHOCK HAZARD - DO NOT REMOVE PANELS. RISK OF EXPLOSION. DO NOT USE IN PRESENCE OF FLAMMABLE ANESTHETICS. FOR CONTINUED PROTECTION AGAINST RISK OF FIRE, REPLACE ONLY WITH SAME TYPE AND RATING OF FUSE.

DANGER:
CET APPAREIL DE RADIOLOGIQUE PEUT ETRE DANGEREUX POUR LE PATIENT ET L'OPERATEUR SI LES FACTEURS D'EXPOSITION ET LES INSTRUCTIONS NE SONT PAS SUIVIES. RISQUE D'EXPLOSION
- NE PAS EMPLOYER EN PRESENCE D'ANESTHESIQUES INFLAMMABLES. POUR ASSURER UNE PROTECTION CONTINUE CONTRE LE RISQUE D'INCENDIE UTILISER UNIQUEMENT UN FUSIBLE DE RECHARGE DE MEME TYPE ET DE MEMES CARACTERISTIQUES NOMINALES.

6
Emergency button label

STOP

5.2 Functions, models and versions

X-MIND prime, manufactured by de Götzen, is a complete panoramic X-ray system that can perform the following exams:

- Panoramic adult or child exams, with 3 sizes and 3 types of biting for a total of 18 combinations with automatic selection; with manual selection, it is possible to select a high voltage between 60kV and 70kV, in 2kV steps and anodic current from 2 mA to 7.1 mA in the R20 scale steps.
- Sinus mode makes it possible to take exams of the paranasal sinuses with front projection (postero/anterior).
- TMJ closed/open mouth in lateral projection.
- Right or Left Half-panoramic, to be used when the patient is known to have a problem only on one side of the arch, in order to reduce radiation.
- Low dose Panoramic, which reduces the dose radiated by excluding the TMJ's ascending rami from the radiograph.
- Frontal dentition, for a radiograph of the front part (roughly from canine to canine).
- Ortho Rad Panoramic, which reduces teeth overlap, thereby improving the diagnosis of interproximal decay.
- Bitewing Left or Right, for lateral dentition (generally from eighth to fourth) with a trajectory that reduces teeth overlap
- Bilateral Bitewing (Left and Right), which sequentially performs both bitewings, showing them on the same image.

Note



The code entered in X-MIND prime to enable additional exams is protected by a unique Identification Code (UIC); in the event the UIC is not present or is faulty, error E270 or E271 will be shown.

The UIC is simply an identifier of the single X-MIND prime unit and is generated by Acteon for the single device serial number.

6. TECHNICAL CHARACTERISTICS

General features

Type	X-MIND prime	
Manufacturer	de Götzen S.r.l. 21057 Olgiate Olona (VA) - Italy	
Class	Class I with type B applied parts according to IEC 60601-1 classification.	
Protection degree	IPX0 standard device	
Line voltage	99-264 V	
Rated line voltage	110-240V	
Line frequency	50/60Hz	
Maximum line current	7A @ 110V 50/60Hz 3.5 A @ 240V 50/60Hz	
Technical factors for maximum line current	70kV, 7.1mA	
Power consumption	1.1kVA @ 110V 50/60Hz 1.0kVA @ 240V 50/60Hz	
Protection fuse (F1)	10 A T 250V 6.3x32 mm 10kA@125V 4 A T 250V 6.3x32 mm 200A@250V	
Column protection fuse (F2)	3 A T 250V 6.3x32 mm 10kA@125V 1.6 A T 250V 6.3x32 mm 100A@250V	
Line apparent resistance	0.4 Ω max (99-132 V) 0.5 Ω max (198-264 V)	
Rated output voltage (kVp)	60 - 70kVp, with 2 kVp steps	
Anodic current	2 - 7.1mA, with R20 scale steps (2, 2.2, 2.5, 2.8, 3.2, 3.6, 4, 4.5, 5, 5.6, 6.3, 7.1)	
Additional filtration	\geq 2 mm Al eq.	

Exposure times

Panoramic exam (PAN)	14.4s Adult / 13.3s Child
Half-panoramic exam	7.8s Adult / 7.3 s Child
Ortho Rad panoramic exam	11.9 s Adult / Child
Low dose panoramic exam	11.9s Adult / 10.8s Child
Frontal dentition	4.4 s Adult / Child
TMJ mouth closed/open	4.8 s per image for left and right joint in open and closed condition
Sinus P/A projection	9.4 s
Exposure time accuracy	± 5 % or ± 20ms whichever is greater

Exam modes

Exam selection	<ul style="list-style-type: none"> • Automatic selection for Adult and Child, 3 Sizes • 3 biting modes (Panoramic exam) • Manual selection
Panoramic exam	<ul style="list-style-type: none"> • Standard panoramic • Half panoramic L/R • Ortho Rad panoramic • Low dose panoramic • Frontal dentition • Bitewing L/R • Bitewing L and R
TMJ (Temporal Mandibular Joint) exam	TMJ open and closed mouth
Sinus exam	Sinus P/A projection

Image magnification	Geometric magnification	Magnification after software correction
Adult / Child standard Panoramic	1 : 1.23 (constant over dentition part)	1 : 1 (*)
TMJ open/closed mouth	1 : 1.20 (nominal)	1 : 1 (*)
Sinus	1 : 1.22 (nominal)	1 : 1 (*)

**(*) Warning**

The declared image magnification value is valid after proper software calibration.

**Note**

X-MIND prime is based on a standard dentition and ascending rami shape.

This shape, based on statistical studies, establishes a form for the dentomaxillofacial complex, adopted as "standard".

X-MIND prime follows a rototranslation path which maintains the magnification factor as stated in the Technical Characteristics of each type of exam as constant along this "standard" shape only along the dentition area. The patient's anatomy can differ significantly from the statistical model, so the magnification factor is not maintained and may be different from the value stated. Based on experience and competence, the user has to judge this variation.

In any case, TMJ radiography cannot be used to perform calculations of distances, angles etc. on the film.

Tube-head characteristics

Model	MPV 05
Manufacturer	de Götzen S.r.l. 21057 Olgiate Olona (VA) - Italy
Maximum tube voltage	70 kVp
kVp accuracy	± 8 %
Maximum anodic current	7.1 mA
Anodic current accuracy	± 10 %
Duty cycle	1 : 16
Reference loading conditions related to maximum energy input to the anode	1125mAs/h @70 kVp
Nominal power	0.50 kW (70 kVp - 7.1 mA)
Transformer insulation	Oil bath
Target angle and reference axis	See Figure 3
Cooling	By convection
Leakage radiation at 1 m	< 0.5 mGy/h @ 70 kVp - 7.1 mA - 3s duty cycle 1/16
Tube-head maximum thermal capacity	310kJ

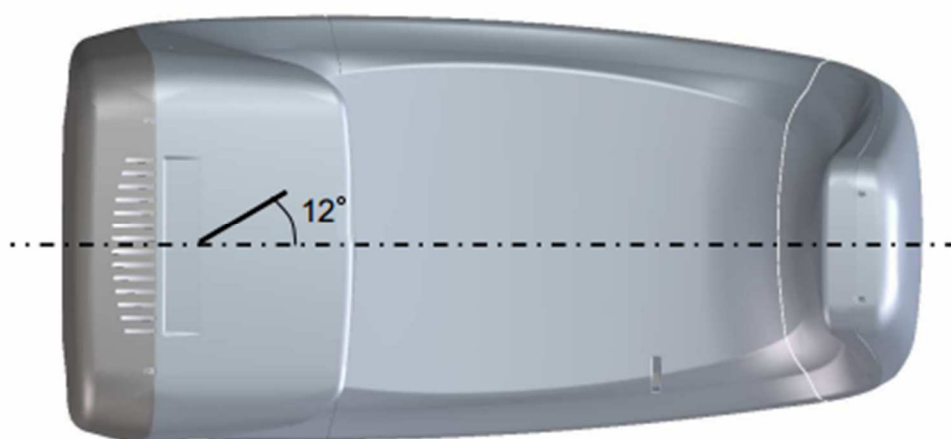

Figure 3: Tube-head target angle (view from the bottom)

X-ray tube characteristics

Manufacturer	Canon	CEI
Type	D-058	OPX 105-12
Nominal focal spot	0.5 EN 60336	0.5 EN 60336
Inherent filtration	At least 1.0 mm Al eq.	0.5 mm Al eq.
Anode tilt	12.5°	12°
Anode material	Tungsten	Tungsten
Nominal maximum voltage	70 kVp	110 kVp
Filament max current	3 A	4 A
Filament max voltage	3.6 V	6.7 V
Anode thermal capacity	13 kJ	30 kJ
Anode thermal capacity during continuous operation	300 W	300 W

Laser centring devices

2 laser beams are used for patient positioning; beams that align the sagittal and Frankfurt planes (please refer to relevant paragraphs for a detailed explanation).

Wave length	650 nm
Divergence	< 2.0 mRad
Optical power on the working surface	< 1 mW
Laser class	Class 2 laser product according to IEC standard 60825-1:2007

Digital sensor

Detector type	FFT-CCD area image sensor
Sensible Area (H x L) PAN Sensor	146 x 6 mm
Pixel dimension	48 µm, 96 µm in 2x2 binning
Number of pixels	3072x128
Spatial resolution	4 lp/mm
Sensor cover attenuation equivalent	< 0.4 mm Al eq.

Mechanical characteristics

Focal spot to image receptor distance	50 cm (20")
Telescopic motorised column run	66 cm (26")
Maximum total height – Note: for the wall mount model this value refers to the recommended installation height	219 cm (86")
Weight	62 kg base version
Column base (optional)	6 kg

Working conditions

Minimum room size (please refer to the Service Manual)	120 x 115 cm ("x")
Recommended room size (please refer to the Service Manual)	160 x 150 cm ("x")
Working temperature range	+ 10°C ÷ + 40°C
Relative working humidity (RH) range	30% ÷ 75%
Temperature range for transport and storage	- 20°C ÷ + 70°C
Humidity range for transport and storage	< 95% without condensation
Minimum atmospheric pressure for transport and storage	630 hPa



Note

Monitor characteristics: the PC and the monitor are not supplied with the equipment.

In order to properly view images taken with X-MIND prime, the PC monitor must have the following minimum characteristics:

- Resolution: 1366 x 768 pixels
- Colour depth: 16M of colour
- Contrast: 500:1
- Luminosity 200cd/m²



Note

The handles of the equipment are covered with a special antibacterial paint which, thanks to the emission of silver ions, prevents the development of micro-organisms.

6.1 Dimensions

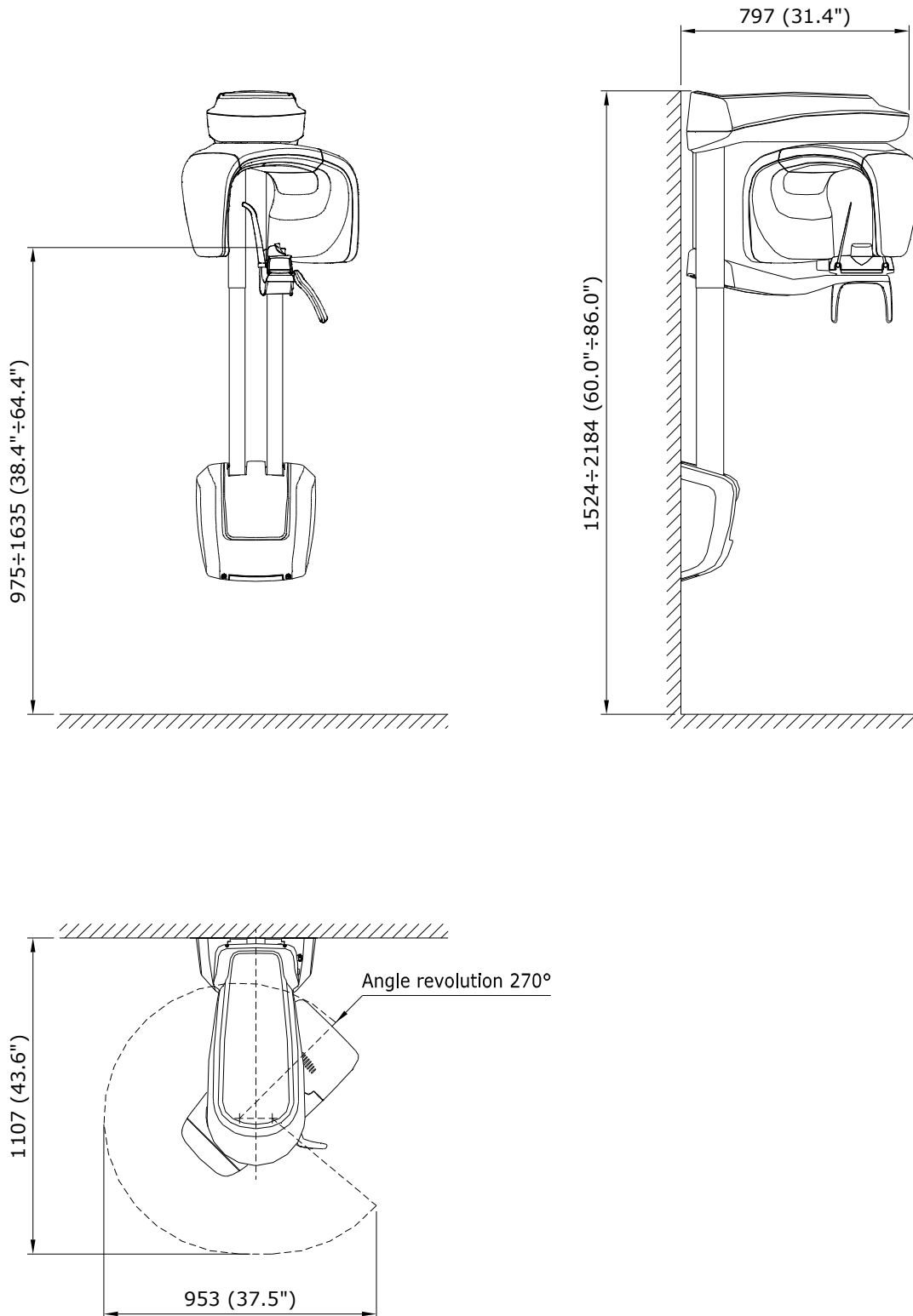

Figure 4: X-MIND prime dimensions - Wall mounted version

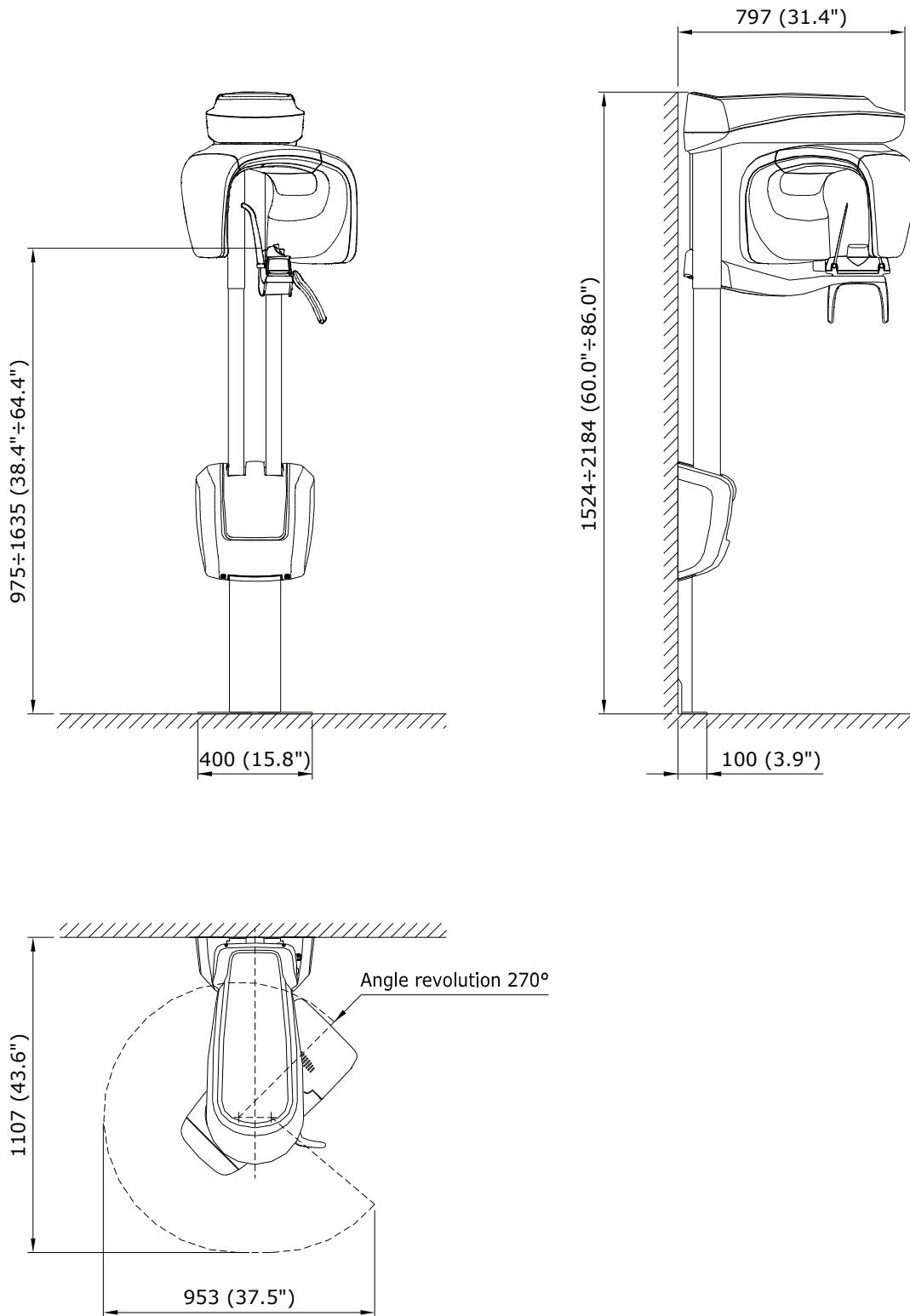

Figure 5: X-MIND prime dimensions - Wall mounted with floor support version

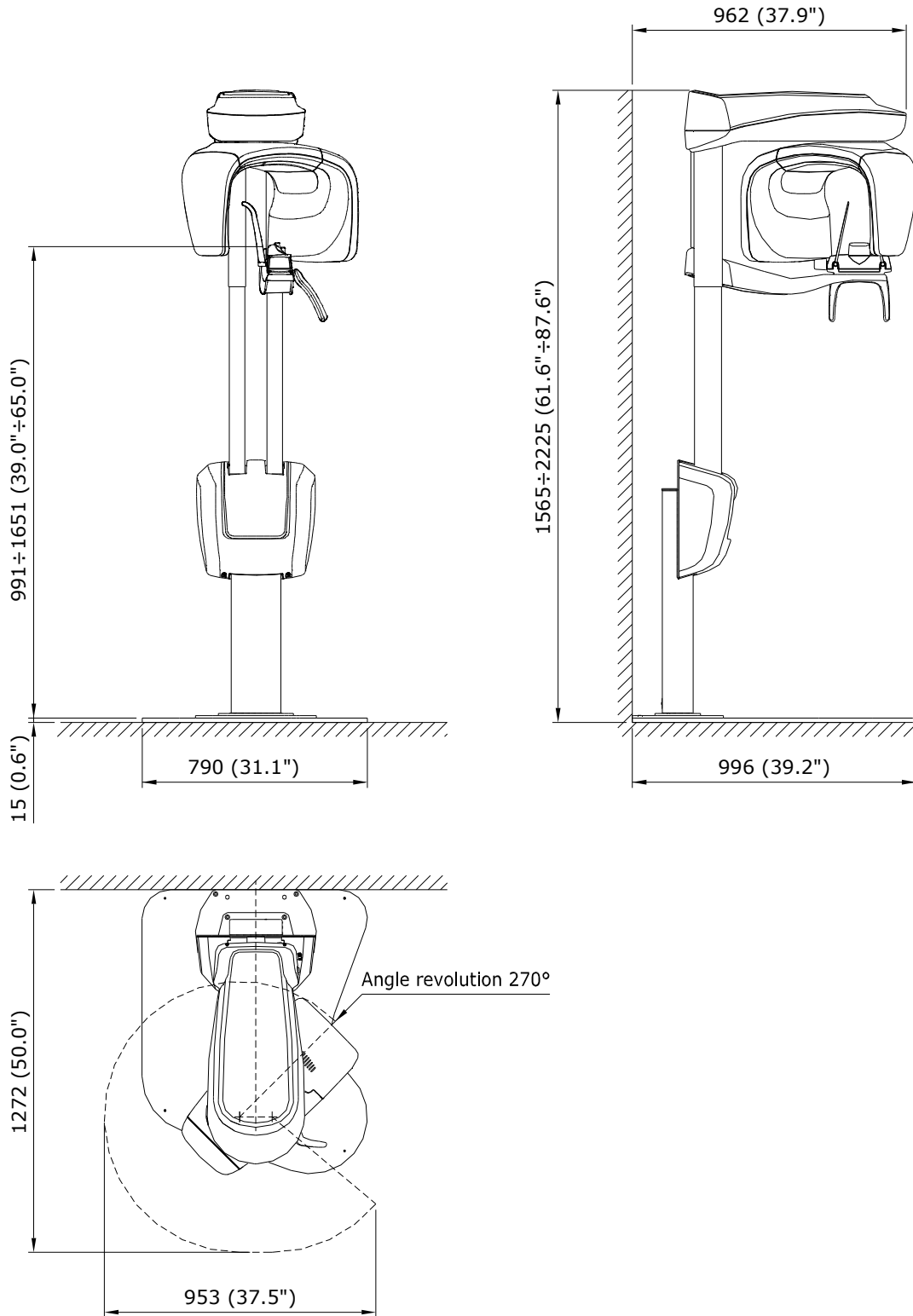
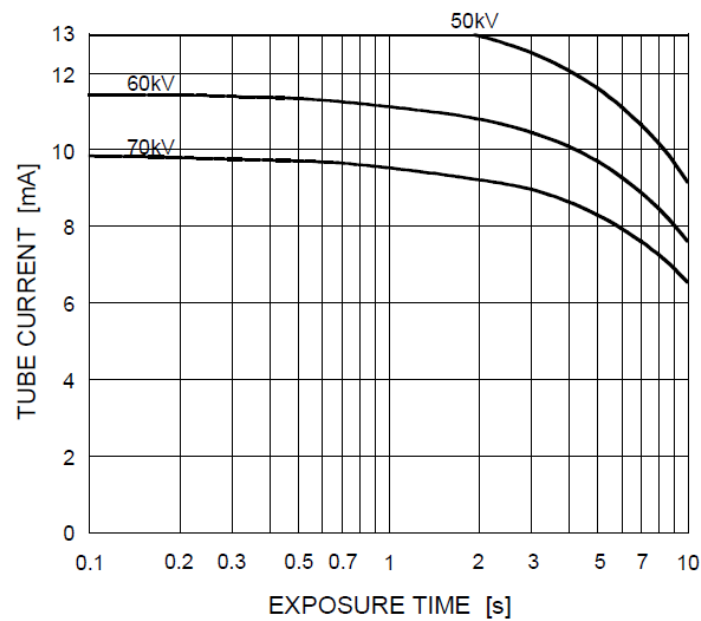

Figure 6: X-MIND prime dimensions - Floor mounted version

6.2 Tube loading curves, anode heating and cooling curves

Tube "Canon D-058" (0.5 IEC 336)

Tube loading curves



Anode heating and cooling curves

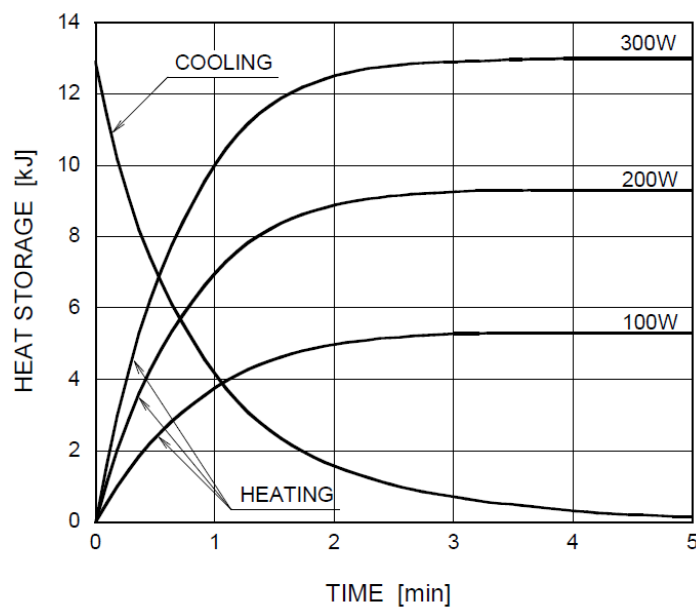

Tube "CEI OPX 105-12" (0.5 IEC 336)

Tube loading curves

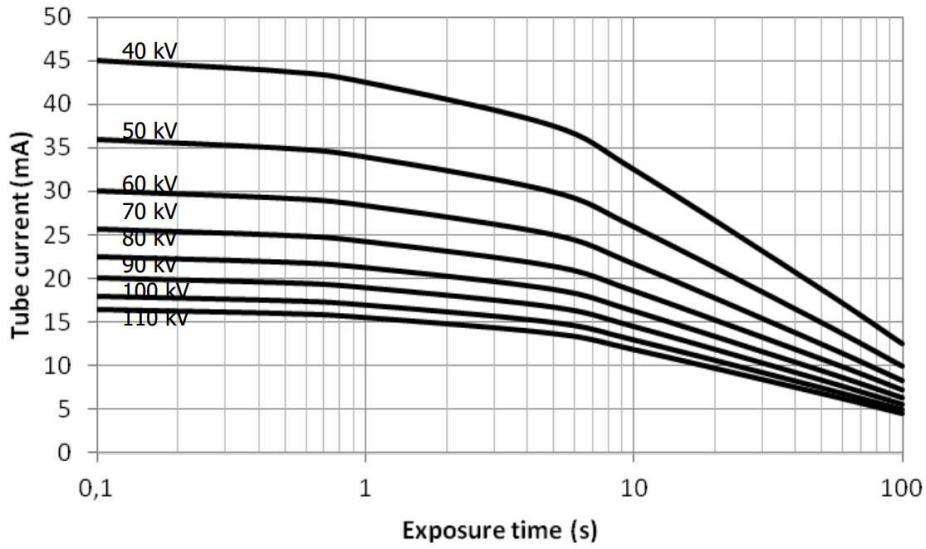

Anode heating and cooling curves

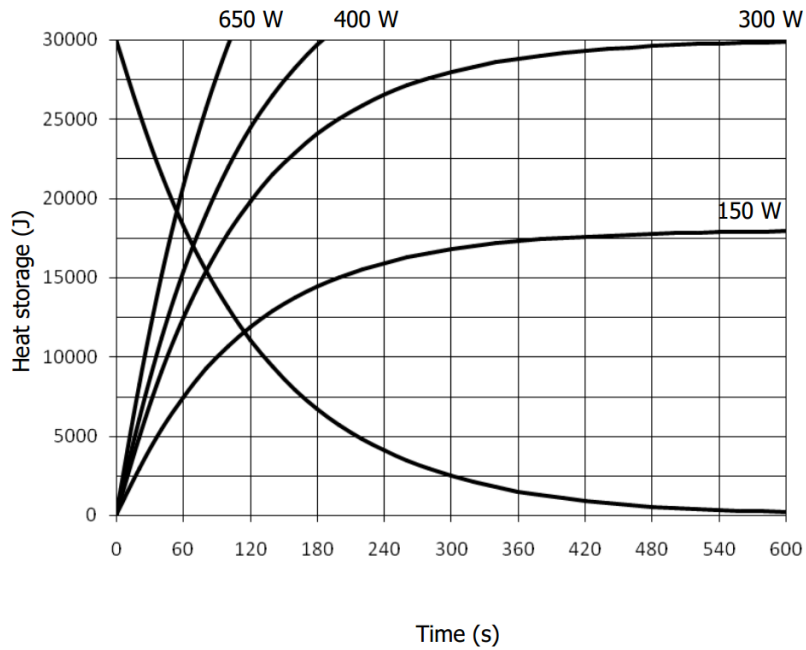

Tube head cooling curve

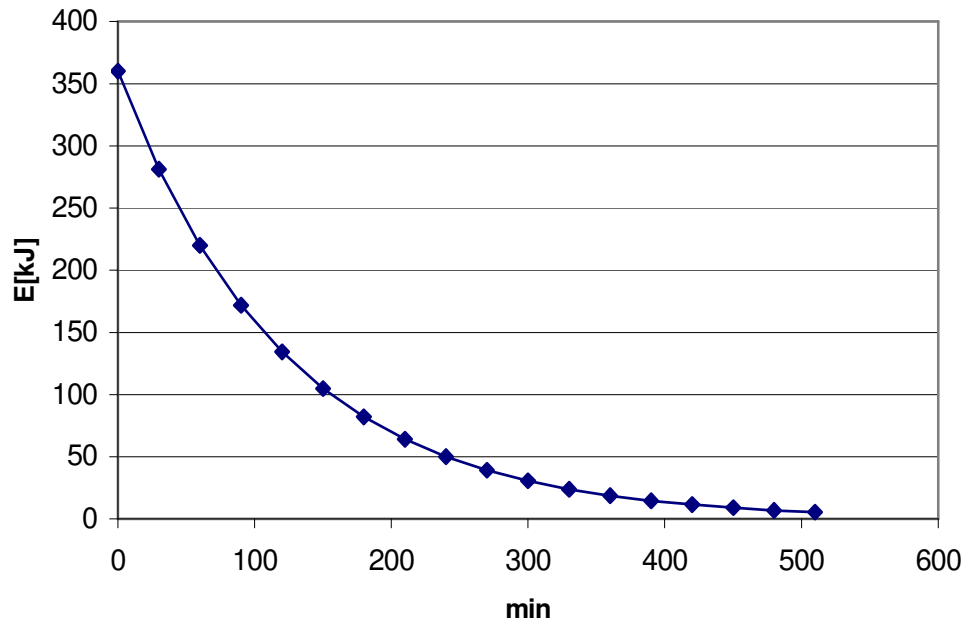

6.3 PC requirements

**Warning**

PC to be used with the machine must comply with the standard IEC 60950-1:2005.

In the following paragraphs are listed the minimum PC characteristics.

6.3.1 PC minimum characteristics

- Mother board with at least one free PCI express X16 slot (mandatory for the Dual Port Network Card provided with the equipment).
- Processor Intel Core i3 (Dual core).
- 2 GB RAM.
- Hard drive 320 GB.
- Operating System Windows 7.
- USB port 2.0.
- 10/100 Ethernet port.

6.4 Software

The equipment Graphical User Interface can be run with the software provided with the machine or integrated in a third party imaging and database software that complies with the following specifications: it has to be CE marked as medical device of class IIa and integrate the equipment SDK according to what stated in the document PANOW3D API programmer's guide Vn (n is the document revision), contact Acteon to have the latest revision of the programmer's document.

6.5 X-MIND prime – PC communication

The communication between X-MIND prime and computer is carried out with a LAN connection based on a TCP/IP protocol.

In order to properly operate the unit, follow carefully the instructions reported in the Service Manual at paragraph 7.6.

The system is provided with an Ethernet cat 5e cable in order to permit the PC connection. In case of replacement, a cable of the same or superior category has to be used.

If the communication between X-MIND prime and PC is not properly set problems in unit connection causing impossibility of acquisition or loss of data causing distortion and artefacts on the images can occur.



Note

X-MIND prime is not intended to transmit or receive information to/or from other equipment through network/data couplings, but with the computer where the unit GUI is activated.

6.6 Reference standard

Medical electrical equipment for extra-oral dental radiography X-MIND prime complies with:

IEC 60601 1: 2005 (3rd ed.)

Medical electrical equipment - Part 1: General requirements for basic safety and essential performance

IEC 60601 1: 2005 (3rd ed.) + Am1:2012

Medical electrical equipment - Part 1: General requirements for basic safety and essential performance

IEC 60601-1-6:2010 (3rd Ed.)

Medical electrical equipment - Part 1-6: General requirements for safety - Collateral Standard: Usability including IEC 62366: Application of usability engineering to medical devices.

IEC 60601-1-6:2010 (3rd Ed.) + Am1:2013

Medical electrical equipment - Part 1-6: General requirements for safety - Collateral Standard: Usability including IEC 62366: Application of usability engineering to medical devices.

IEC 60601-1-2:2007 (3rd Ed.)

Electromagnetic compatibility - Requirements and tests.

IEC 60601-1-2:2014 (4th Ed.)

Electromagnetic disturbances - Requirements and tests.

IEC 60601-1-3:2008 (2nd Ed.)

Medical electrical equipment - Part 1-3: General Requirements for Radiation Protection in Diagnostic X-Ray Equipment.

IEC 60601-1-3:2008 (2nd Ed.) + Am1:2013 (ed. 2.1)

Medical electrical equipment - Part 1-3: General Requirements for Radiation Protection in Diagnostic X-Ray Equipment.

IEC 60601-2-63:2012 (1st ed.)

Medical electrical equipment - Part 2-63: Particular requirements for the basic safety and essential performance of extra-oral dental X-ray equipment.

IEC 60601-2-63:2012 (1st ed.) + Am1:2017 (ed. 1.1)

Medical electrical equipment - Part 2-63: Particular requirements for the basic safety and essential performance of extra-oral dental X-ray equipment.

IEC 62366:2007 (1st Ed.)

Medical devices – Application of usability engineering to medical devices.

IEC 62366:2007 (1st Ed.) + Am1:2013

Medical devices – Application of usability engineering to medical devices.

IEC 62304:2006 (1st Ed.) + Ac:2008

Medical devices software – Software life-cycle processes.

IEC 62304:2006 (1st Ed.) + Am1:2015 (ed. 1.1)

Medical devices software – Software life-cycle processes.

IEC 60825-1:1993 (1nd ed.)

Safety of laser product – Part 1: equipment classification and requirements.

IEC 60825-1:2007 (2nd ed.)

Safety of laser product – Part 1: equipment classification and requirements.

EN-ISO 14971:2012
Medical Devices - Application of Risk Management to Medical Devices.

CAN/CSA-C22.2 No 60601-1:08
Canadian National deviations to IEC 60601-1.

CAN/CSA-C22.2 No 60601-1:14
Canadian National deviations to IEC 60601-1.

ANSI/AAMI ES60601-1:2005/A2:2010
US National differences to IEC 60601-1.

ANSI/AAMI ES60601-1:2005/(R)2012 and A1:2012
US National differences to IEC 60601-1.

CFR 21
Code Federal Regulation. Sub Chapter J.

 0051 Guarantees the compliance of X-MIND prime with Directives 93/42/EEC (as amended), 2011/65/EU, 2006/42/EC.

The manufacturer (according to the European Directive 93/42/EEC) of the unit X-MIND prime is:

de Götzen S.r.l.
Via Roma 45
21057 OLGiate OLONA (VA) - ITALY
Tel: +39 0331 376760
Fax: +39 0331 376763

Classifications

X-MIND prime is an electrical medical X-ray device classified as class I type B according to EN 60601-1, with continuous operation at an intermittent load.

According to 93/42/EEC Medical Devices Directive, the equipment is classified as class II B.

According to Canadian MDR, the equipment belongs to class II.

According to FDA 21 CFR, the equipment belongs to class II.



7. QUALITY ASSURANCE PROGRAM

Here following the list of the operation required to maintain the continued proper functioning of the unit:

Frequency	Type of check	Done by	Reference
Daily	Functioning of the indicator lights	User	Paragraph 7.2
Daily	Laser alignment check	User	Paragraph 7.3
Monthly	Image quality check	User	Paragraph 7.4
Yearly	Dosimetry test	Authorized personnel	Paragraph 7.5

7.1 Quality check tools

The following tools are required to perform the quality check:

- Support plate (P/N 6195170100): used to check laser alignment and to hold the centering tool (P/N 6195170200)
- Centering tool (P/N 6195170200): used to check image quality
- A.I.S. software: used to acquire image and perform measurements
- SyMage software: used to perform measurements on the image. The SyMage.exe is located at C:\Program Files (x86)\Acteon Imaging\Panoramic X-Mind prime\SyMage
- PhD_Test software: used to perform exposure without arm rotation. The PhD_Test.exe is located at C:\Program Files (x86)\Acteon Imaging\Panoramic X-Mind prime
- kV meter (NOT provided with the equipment): used to measure exposure parameters.

Except kV meter, all these tools are provided with the unit.

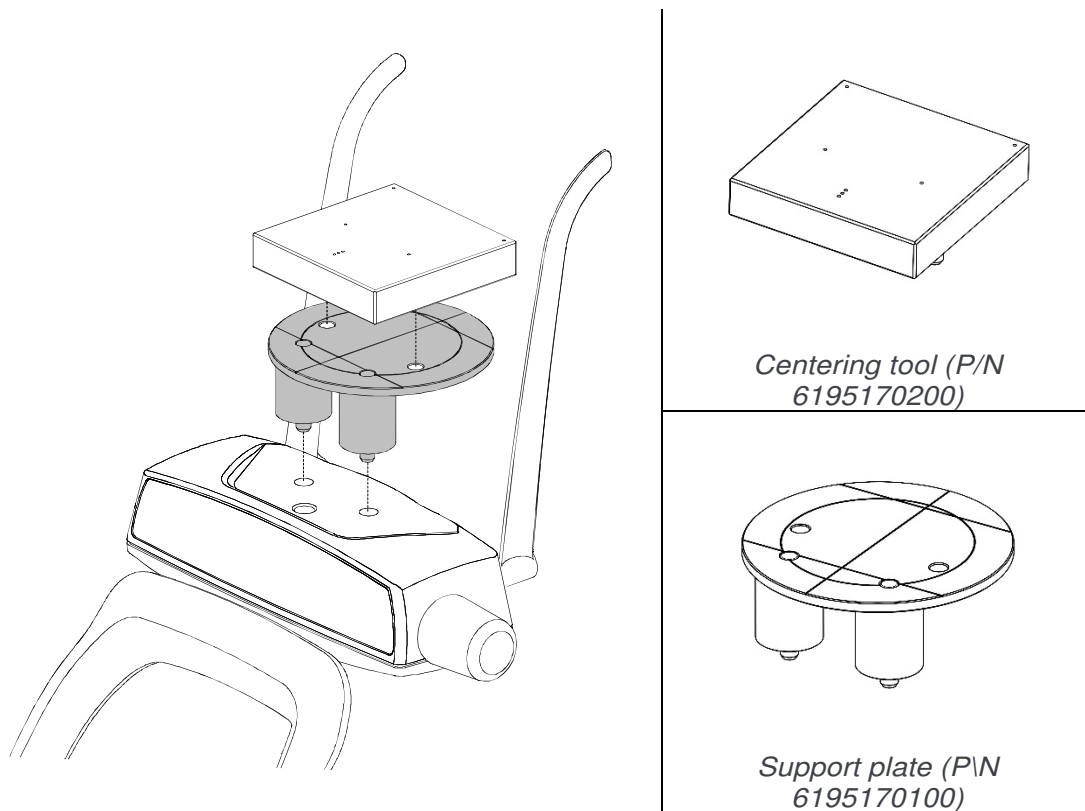

Figure 7: Support plate and centering tool positioning

7.2 Functioning of the indicator lights

Power ON the unit, verify that the "Machine Ready" (1), "X-Ray Emission" (2) and "Computer connection" (3) LEDs light for few seconds.



Figure 8

In case the test fails, verify that the main power supply is present in the room. If the case, call technical assistance.

7.3 Laser alignment check

Power ON the unit and perform the axis reset by pressing the >0< button.

At the end of the axis positioning, place the support plate (P/N 6195170100 - Figure 7) on the chin rest support and power ON the laser. Check that the mid-sagittal laser beam is aligned to the reference line of the support plate ($\pm 3\text{mm}$).

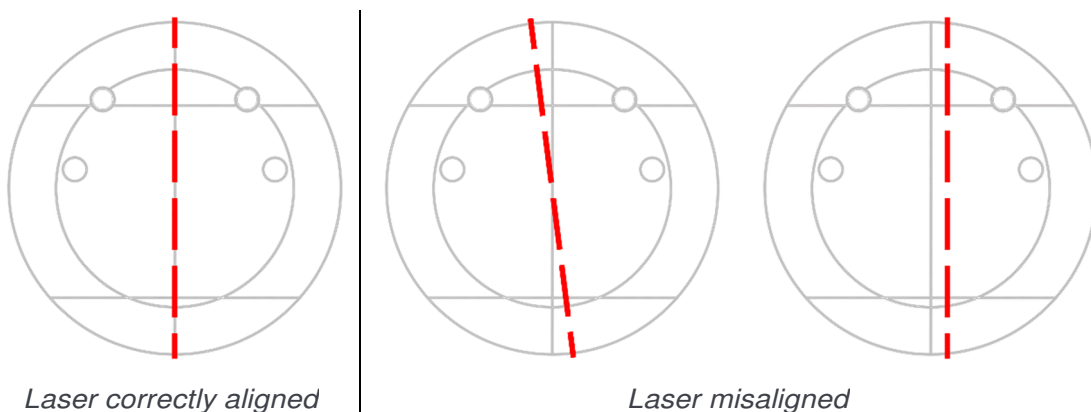

Figure 9

In case the test fails, repeat it checking that there is no mechanical interference. If misalignment is still present, call technical assistance.

7.4 Image quality check

7.4.1 Geometry check



Warning

X-rays will be emitted during the performance of the following operations. It is recommended to use the greatest caution and to comply with local safety regulations and laws.

1. Switch ON the unit and go to Exam Selection.
2. Open AIS software and open the patient "Quality Test". If not present, create a new patient (Name: "Quality"; Family name: "Test").
3. From the top toolbar, select the Panoramic icon to open the X-MIND prime interface

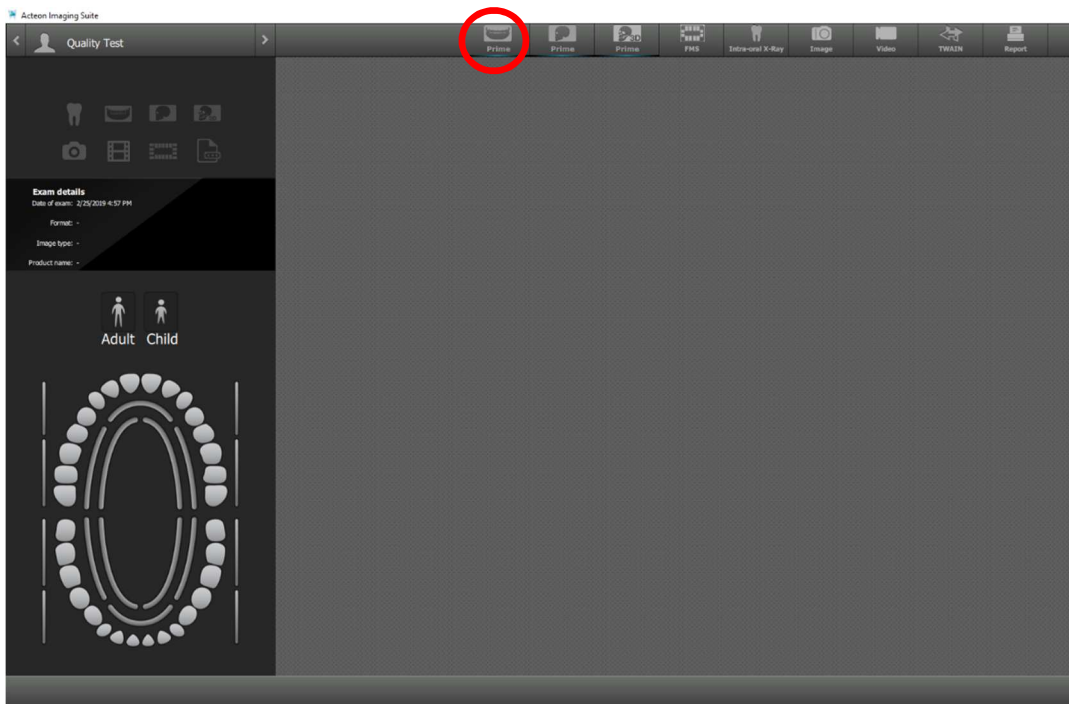

4. Mount the centering tool on the support plate, and place it on the chin rest support (Figure 7).
5. On the virtual keyboard, select Standard Panoramic – Adult – and make an exposure at 66kV, 5mA.
6. Select the "Ruler" icon and measure the distance between the two external spheres; this value must be $169\text{mm} \pm 2\text{mm}$.

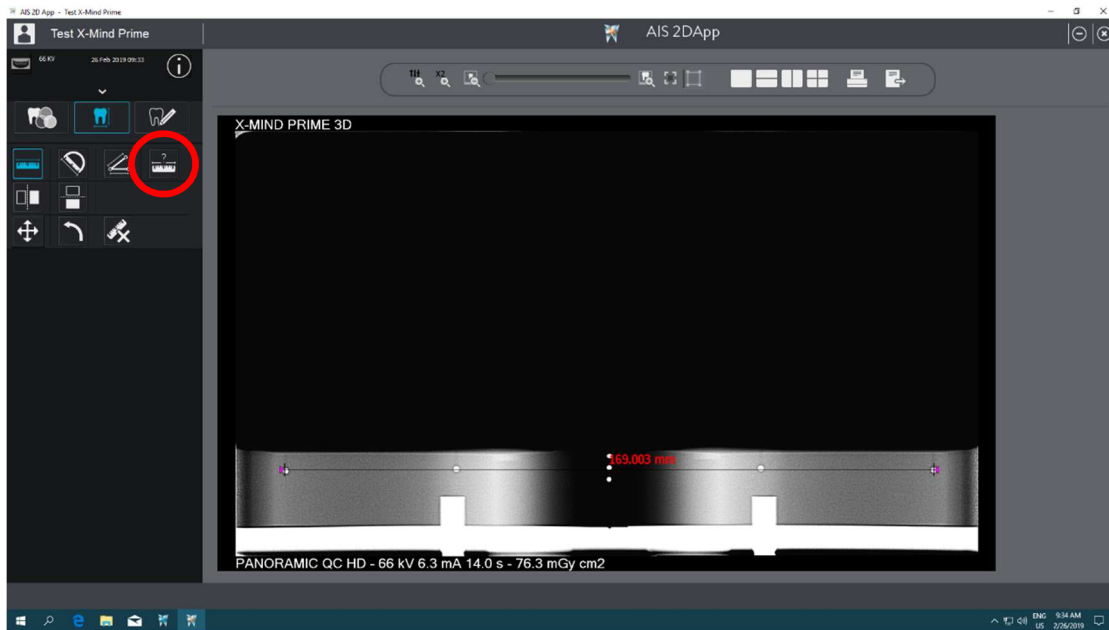

In case the test fails, call technical assistance.

7. Measure the distance between the left external sphere and the central one and the distance between the right external sphere and the central one: the difference of these values must be maximum 2mm.
In case the test fails, call technical assistance.
8. Record the tests results in the log book at paragraph 7.6.1.

7.4.2 Signal to noise check

1. In AIS, open the patient "Quality Test".
2. Right-click on the image taken in the previous paragraph and select "Export Image" from the drop-down menu. Save the image on the Desktop.

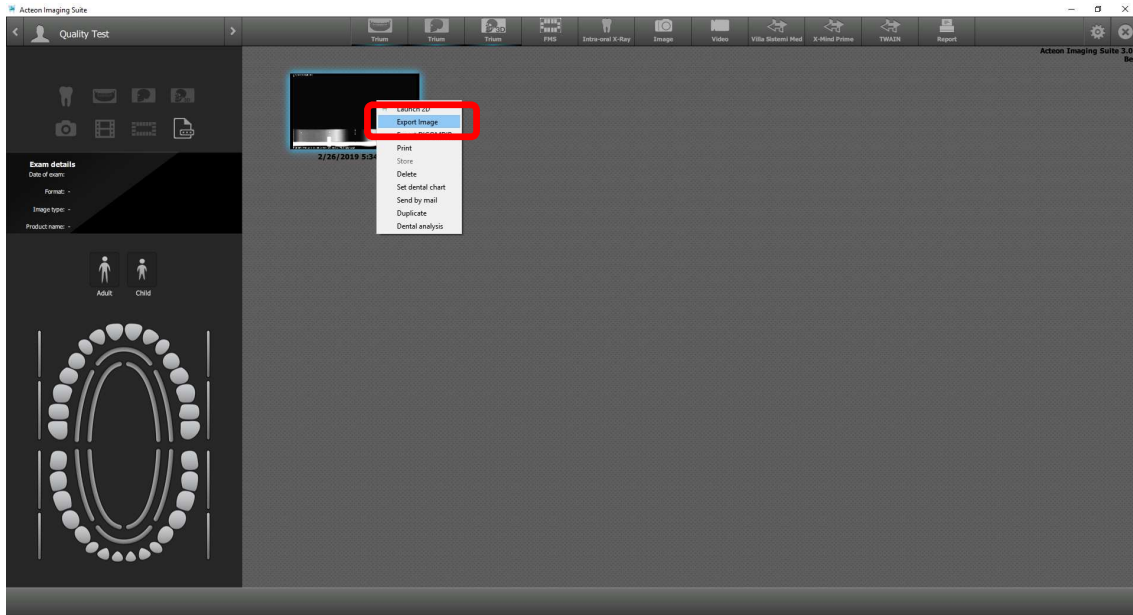

3. Open SyMage program and open the image previously saved on the Desktop.
4. Select the tool "Rectangle Selection" from the palette, and draw a region on the uniform area of the centering tool as shown in the figure below:

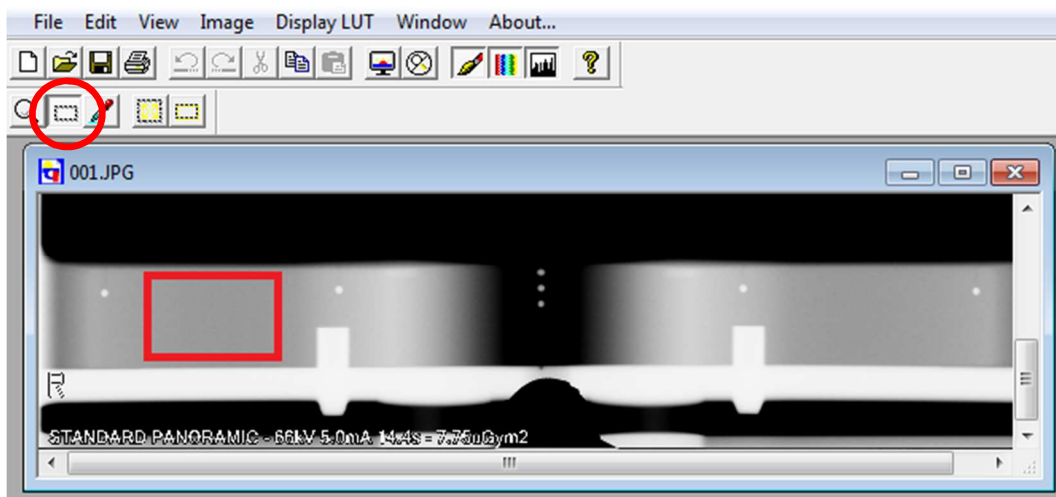

5. Check the window "Statistics": the S\N (db) value has to be higher than 25.

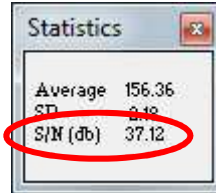

Statistics	
Average	156.36
ST	3.12
S/N (db)	37.12

Record the test results in the log book at paragraph 7.6.1.

In case the tests fail, call technical assistance.

7.5 Dosimetry test (paragraph for authorised personnel)



Note

The dosimetry test has to be performed only by authorized personnel. The present paragraph explains the procedure for dosimetry test with non-invasive method. For further details, please refer to Service Manual.



Warning

The device collimator gives a narrow X-ray beam. Measurement taken with non-invasive method and a narrow beam can be difficult and/or unreliable; it is therefore necessary to use a special probe with a reduced sensitive area. It may be helpful to use a fluorescent screen to locate the X-ray beam and consequently position the probe of the kV meter.

1. Place the probe of the dosimeter on the sensor plastic cover.
2. Open the PhD_Test software (located at C:\Program Files (x86)\Acteon Imaging\Panoramic X-MIND prime) and check that the unit is connected to the PC (the message "MCU is connected" is displayed in the bottom left corner of the program window).
3. From the "Exam parameters" panel select the ID as "Centring panoramic".

Exam parameters	
ID	Centring panoramic
Format	Panoramic collimator
Resolution	High
Params1	Unused
Patient	Adult
Biting	Standard
kV	60
mA	5.0



Note

The "Centring panoramic" choice allows you to carry out the dosimetry test without the rotation of the tube-head arm.

- In the "Sensor centring parameters" panel set the following exposure parameters: 60 kV, 3 mA, 3 s.

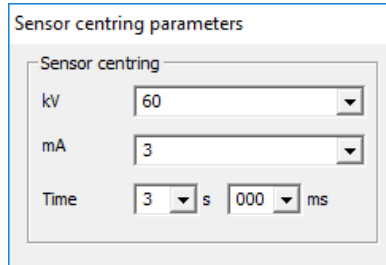

- Press the X-ray button to take an exposure and verify that the measured values are in the acceptance limits listed in the Table at point 6.
- Take a second exposure setting the following parameters: 70 kV, 6 mA, 3 s and verify that the measured values are in the acceptance limits listed in the following table.

kV	mA	t (s)	kV acceptance limits	Time acceptance limits
60	3	3	55.2 to 64.8 kV	2.85 to 3.15 s
70	6	3	64.4 to 75.6 kV	2.85 to 3.15 s

- In case the test fails (result do not match the indicated values), proceed with the following actions:
 - Check the probe position and repeat the test
 - If the values are still out of range, perform the test using the invasive method as described in the Service manual, paragraph 9.7
 - If the values are still out of range, call technical assistance.
- Record the test results in the log book at paragraph 7.6.2.



7.6 LOG book

7.6.1 Image quality check

	Dimension	Symmetry	Signal to noise
Acceptance range->	167 - 171 mm	≤ 2 mm	≥ 25 dB
Date	Measured value	Measured value	Measured value



7.6.2 Verification of radiological parameters

Parameter set ->	60 kV, 3 mA, 3 s		70 kV, 6 mA, 3 s	
Acceptance range->	55.2-64.8 kV	2.85-3.15 s	64.4-75.6 kV	2.85-3.15 s
Date	kV measured	Time measured	kV measured	Time measured

8. GENERAL INSTRUCTIONS FOR USE

8.1 Switching the device ON and OFF



Warning

The unit must be connected to a differential magneto-thermal switch to divide the unit from the supply. This switch must comply the electrical regulations in force in the country of installation.

Minimum requirements at 230V: working voltage 250V, current 10A and differential current 30 mA.

Minimum requirements at 115V: working voltage 150V, current 25A and differential current 30 mA.

Press the power switch located on the upper part of the equipment on the operator side to position "1".

This will start the "CHECK" function, which is indicated by LEDs lighting up on the equipment keyboard.

When the "CHECK" function is complete, the green LED (3 - Figure 10) on the equipment keyboard starts blinking.

To carry out an exam follow the instruction from paragraph 8.6.

To switch OFF the unit press the power switch located on the upper part of the equipment on the operator side to position "0".

The LEDs will go off.

8.1.1 Emergency button

The equipment has a red emergency button located on the upper part of the unit, near the power switch.

The emergency button only stops the vertical column movement.

In case of an emergency column situation, press the emergency button to stop the movement.

If columns don't move, check that the emergency button is not pressed; rotate the button to release it.

8.2 Positioning the chin support

X-MIND prime is equipped with different types of supports: a standard support fitted with a special removable appendix for edentulous patients, a lower one for SINUS exams and a third one TMJ exams.

The standard chin support must be used, in panoramic mode, with all patients who can ensure a tight grip on the centring bite. The appendix for edentulous patients must be applied only for patients who cannot ensure a tight grip on the bite or are not co-operating and might move during the exam.

For SINUS exams, there is special support; being in a lower position, this ensures a better centring of the area concerned in the rays field.

For TMJ exams, a specific positioner is included, allowing the patient to open and close the mouth without touching any positioner with the chin.



Note

Another chin support, lower in height, can be used in standard panoramic exams to ensure a better view of the lower section of the chin for patients with a particular anatomy. This chin support is marked by a down arrow "▼" on the front of the chin support itself.

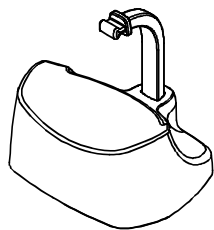

Panoramic standard chin support

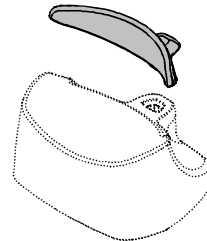

Edentulous patients appendix

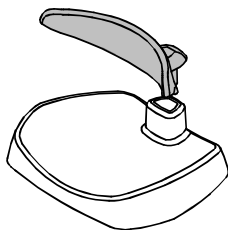

SINUS chin support

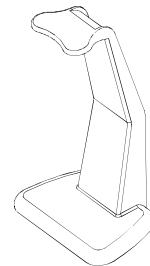





TMJ positioner



8.3 Keyboard - Description and functions

Figure 10 shows a general view of X-MIND prime control Interface.



Figure 10: Keyboard

Label	Description	
1	The up/down movement of the column is controlled by the corresponding keys. The movements are enabled during equipment setting. Column movement is not possible if the emergency button is pressed.	
2	The "Luminous centring device" key turn the laser centring devices ON/OFF, allowing the correct positioning of the patient.	
3	Light indicator of "Machine Ready" status: <ul style="list-style-type: none"> • Green fixed, alerts the user that by pressing the X-ray button, X-ray emission will start • Green blinking slowly, indicates that by pressing >0< button, axis reset will start, • Green blinking fast, indicates the equipment cooling status. 	
4	Light indicator "X-Ray Emission" status. It indicates the emission of X-rays.	

Label	Description	
5	Light indicator of "Computer connection" status: <ul style="list-style-type: none">• Blue fixed, computer connection established,• Blue blinking slowly, waiting for computer connection. No X-ray emission available• Blue blinking fast, the equipment is in error state. Refer to the GUI for error description.	
6	The "Centring/Patient Entrance" key is used to: <ul style="list-style-type: none">• Start/Stop the exam procedures• Put the rotation arm in the patient entrance position at the end of the exam.	
7	Temple clasps closing/release knob.	

8.4 Graphical User Interface - Description and functions

All unit configuration is managed via the virtual interface (Figure 11) running on the computer. This interface enables the user to configure all technical features of the unit, to choose and adjust the exam and radiological parameters.

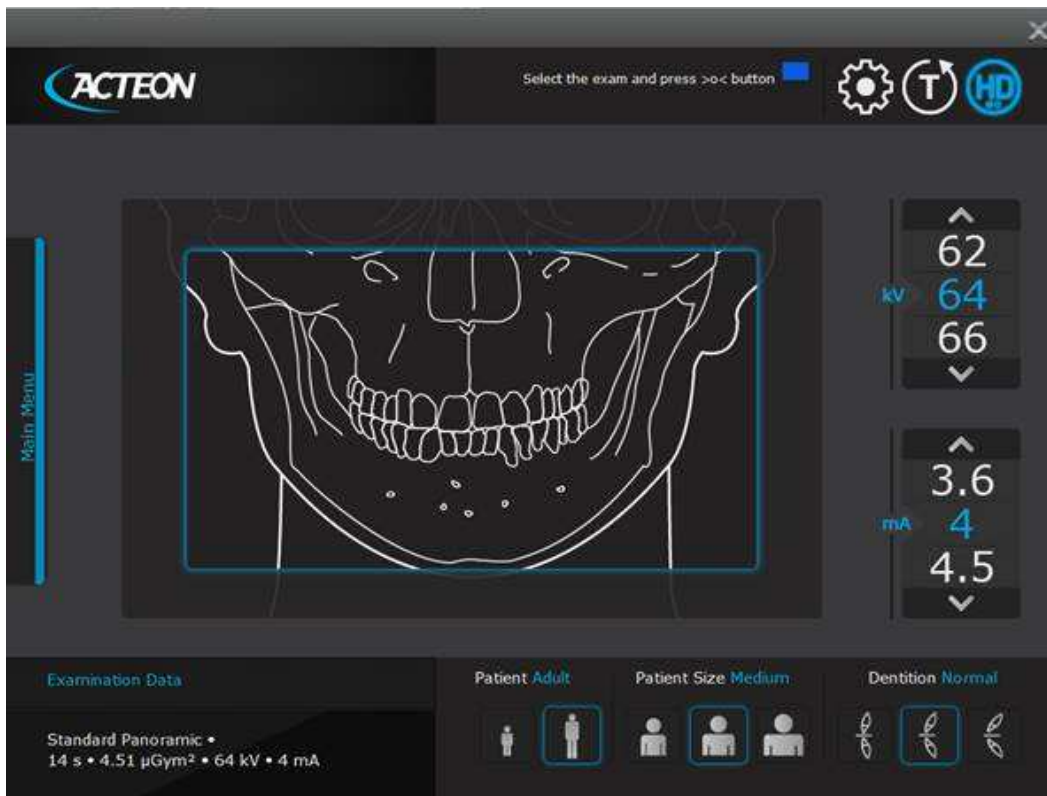







Figure 11

<p>Adult/Child selection: the pre-set exposure values and in panoramic exam the trajectory, are automatically updated based on the current selection.</p>	
<p>Patient size selection: Small/Medium/Large. The pre-set exposure values will be automatically updated based on the current selection.</p>	
<p>Patient's type of biting: Protruded/Normal/Retracted. This selection is only available in Panoramic mode. The position of the focus layer will be automatically updated based on the current selection.</p>	
<p>Test mode selection: disables X-ray emission. Use the test mode to check for the absence of collision with the patient. Test mode may also be useful when the equipment is used on child patients, to show them how the equipment works before running the exam.</p>	

<p>Setting: open the setup menu.</p>	
<p>HD selection: enables/disables the High Definition Mode (not yet available).</p>	
<p>Virtual LED: indicates the current status of the unit: Blue = Initialization Green = Ready Red = Error Yellow = X-Ray emission</p>	
<p>Exposure parameters selection: changes kV and mA. When the exposure parameters are manually changed, the mode indicator switches from "Anatomic" to "Manual". Return to "Anatomic mode" using the main programme selection key.</p>	
<p>Main menu: selects exam modality, exam type and sub-menu including the available exams.</p>	

8.4.1 Main GUI area functions

In the main area of the Virtual Interface, a picture shows the anatomical region matching the corresponding selected exam.

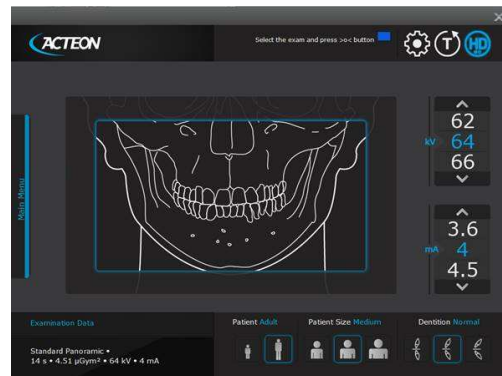

Click on Main Menu to open the exam selection menu. After selecting the exam mode (i.e. Panoramic), the user can choose further options (i.e. Half Panoramic Left).

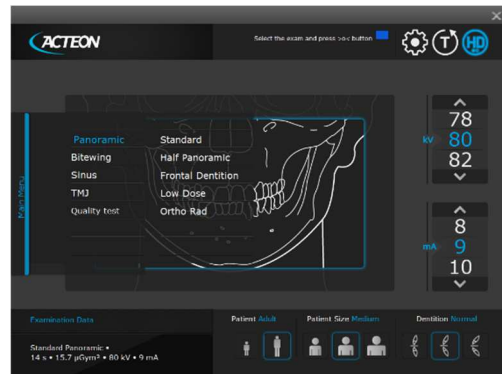

The user can choose from different options.

- Adult/Child: the suggested pre-set exposure values (see paragraph 8.11) will be automatically loaded. For Panoramic exams with child selection, the exposure values and the trajectory length are reduced
- Patient Size: the correct pre-set exposure values will be automatically loaded
- Biting type: the position of the focus layer will be automatically adjusted
- kV/mA selection: the user can manually change the exposure parameters

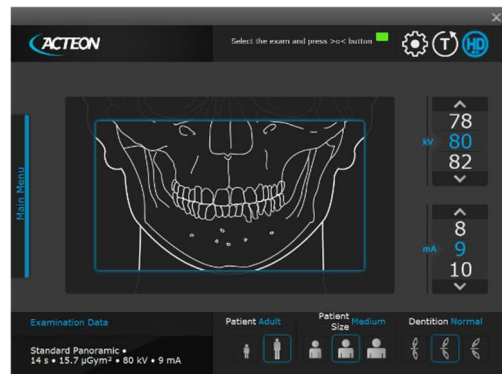

A virtual LED indicates the current status of the unit, while a virtual display shows all service messages related to the current status of the unit and possible error messages.

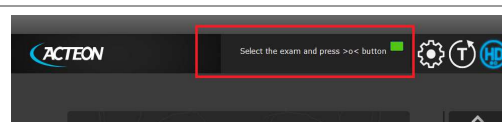

Close to the virtual display there are three different keys that may be selected by the user: Settings, Test mode (enable/disable), HD mode (enable/disable)

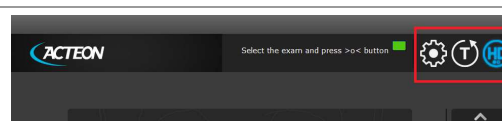



8.5 Digital sensor

The new X-MIND prime is equipped with a PAN sensor: it is a sensor suitable for Panoramic-type imaging, i.e. all images with about 14cm-high field; all Panoramic, TMJ, and Sinus images belong to this type.

The new X-MIND prime control system checks the consistency of safety measures that allow for correct use of the digital sensor; in particular to prevent acquisition when the image management and processing system is not ready to receive the image, it displays the message "Sensor not ready".

8.6 Making an exam

Press the power switch located on the upper part of the equipment on the operator side to position "1". This will start the "CHECK" function, which is indicated by the LEDs lighting up.

When the "CHECK" function is complete, the green LED on the equipment keyboard starts blinking.

To make an exam, proceed as follows:

- Press >O< button on the keyboard to run the equipment axis zero;
- Run the Virtual Interface on the PC and wait for the connection between the PC and equipment; this status is indicated by the blue LED lighting up on the keyboard and on the Virtual Interface;
- Select the exam and parameters on the Virtual Interface;
- Position the proper chin support;
- Position the patient with the help of the lasers (see paragraph 8.8 for Panoramic and Bitewing, paragraph 8.9 for Sinus and 8.10 for TMJ exams) then close the temple clasps;
- Press >O< button to put the equipment in the start exam position; the green LED lights up: the unit is now ready for X-rays;



Note

In the start exam position, the laser light and column movement are not enabled, and on the GUI only kV and mA adjustment is allowed.



Note

Ready for X-ray status is signalled by the green LED on the equipment (3 - Figure 10) and on the GUI lighting up.

Ready for X-ray status remains as long as the equipment is in the start exam position and the GUI is connected to the equipment.

- Press the X-ray button for the entire duration of the exposure;
- Once the exposure is completed, the system will rotate back to patient exit position. Press >O< to return to axis 0 position; it is now possible to free the patient from the positioning device.



Note

With paediatric patient it is recommended to have a greater attention in taking exams. Useful information and a specific checklist can be found at the Image Gently website (www.imagegently.org).

In general with child and adolescent patients, before taking the exposure it is suggested to run the exam in test mode in such a way to show the young patient how the unit works and make them feel comfortable.

8.7 Anatomic / Manual exposure

**Note**

If the previous exam was carried out manually, press the "Size Selection" key to return to automatic mode.

After setting the equipment, the following two operating modes may be chosen:

- ANATOMIC: with the kV and mA values programmed on the basis of the type of patient and size.
- MANUAL: with the possibility to vary the kV and mA values already set.

**Note**

The exam parameters set as the default are values to be taken as the starting point. Users can optimise the parameters according to their needs.

8.7.1 Anatomic exposure

Select the type of patient with the Adult/Child icons. If child option is selected, exposure parameters are lower respect to the corresponding adult programs. In addition, the exam trajectory in panoramic programs is reduced of about 10%.

Select the type of build with the Size icons (small - medium - large).

On the basis of these selections, the display will show the kV and mA settings accordingly.

Select the type of biting with the icon "Type of Biting Selection" (option available in Panoramic mode only).

**Note**

The exam parameters set as the default are values to be taken as the starting point. Users can optimise the parameters according to their needs.

**Note**

The type of biting does not affect the kV and mA values, but it affects the position of the focus layer, by adapting rotation movement to the patient's anatomy.

8.7.2 Manual exposure

If the pre-set kV and mA pairs are not considered suitable for a specific exam, new parameters can be set in manual mode.

To modify the kV or mA values, press any of the up or down cursors of the KV or mA parameters.

A parameter can be modified by pressing the increase key and the decrease key of the parameter repeatedly.

The kV value can vary between 60 and 70 kV, with 2 kV steps.

The mA value can vary between 2 and 7.1 mA according to the r20 scale.

8.8 Panoramic and Bitewing exams

8.8.1 Laser references

Patient centring is assisted by two linear luminous laser beams, which indicate the position of the sagittal medial plane and the Frankfurt plane; the corresponding patient plane needs to be aligned with these laser lines.

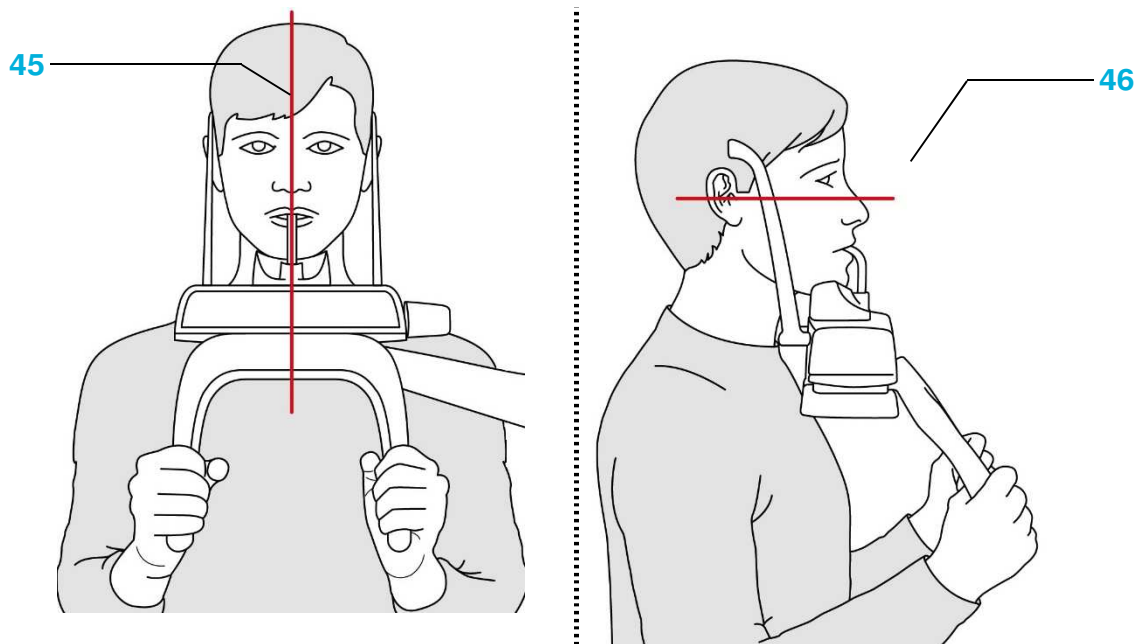

Legend of Reference Lines

- 45 Mid-sagittal line
- 46 Frankfurt plane line: plane that identifies a line that ideally connects the hole in the auricular canal – external auditory meatus - with the bottom edge of the orbital fossa

Figure 12

8.8.2 Preparation of the device

When the unit is switched ON, Panoramic exam mode is selected as standard. If the operator has previously carried out another kind of exam, use the main window in extended view to select Panoramic mode.

The system positions itself with the following configuration:

- ADULT with the display of the corresponding graphic for the key
- MEDIUM SIZE with the display of the corresponding graphic for the key
- NORMAL DENTITION with the display of the corresponding graphic for the key
- default exposure parameters (if this is the first panoramic exposure), or the exposure parameters of the last exposure performed.

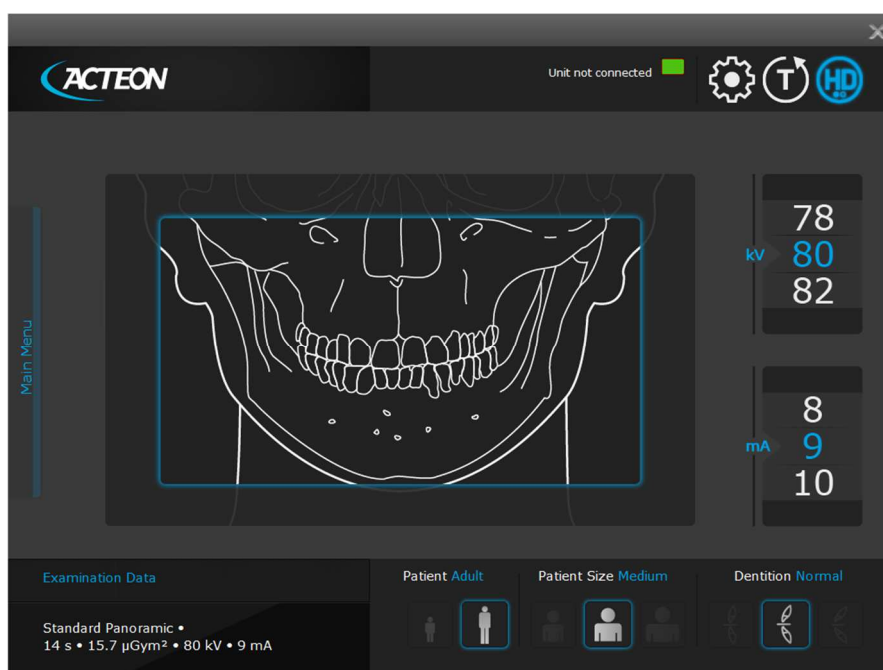

Figure 13

Select the type of patient with the Patient icons (Adult - Child).
 Select the type of build with the Patient Size icons (Small - Medium - Large).
 Select the type of biting with the Dentition icons (Protruded - Normal - Retracted)

On the basis of the selections made, the display will show the kV and mA settings, as in the tables:

Exposure values in PAN mode				
	Adult Patient (14.4 seconds)		Child Patient (14.4 seconds)	
	kV	mA	kV	mA
Small	64	5.6	64	4.5
Medium	66	5.6	66	4.5
Large	68	5.6	68	4.5

Exposure values in Bitewing mode				
	Adult Patient (14.4 seconds)		Child Patient (14.4 seconds)	
	kV	mA	kV	mA
Small	64	5.6	64	4.5
Medium	66	5.6	64	4.5
Large	68	5.6	68	4.5



Note

The exam parameters set as the default are values to be taken as the starting point. Users can optimise the parameters according to their needs.

Once the settings have been completed, the chin support must be placed in position.

The following selections are possible for the Panoramic exam range:
 < Standard - Half Panoramic - Frontal Dentition - Low Dose - Ortho Rad >

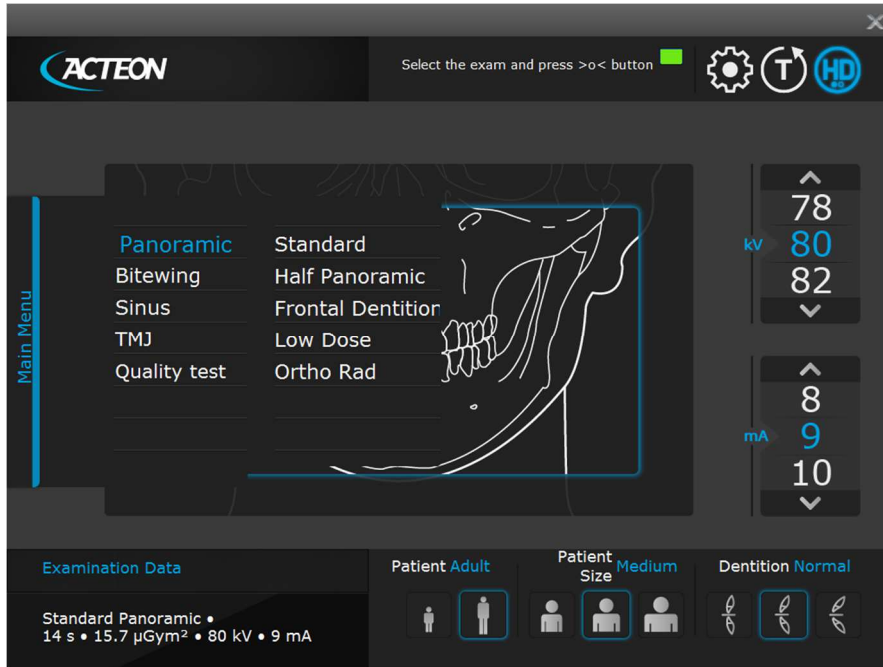

Figure 14: Panoramic exam range

The following selections are possible for the Half Panoramic exam range:
 < R (Right) - L (Left) >
 The selection is done clicking on the corresponding side of the image

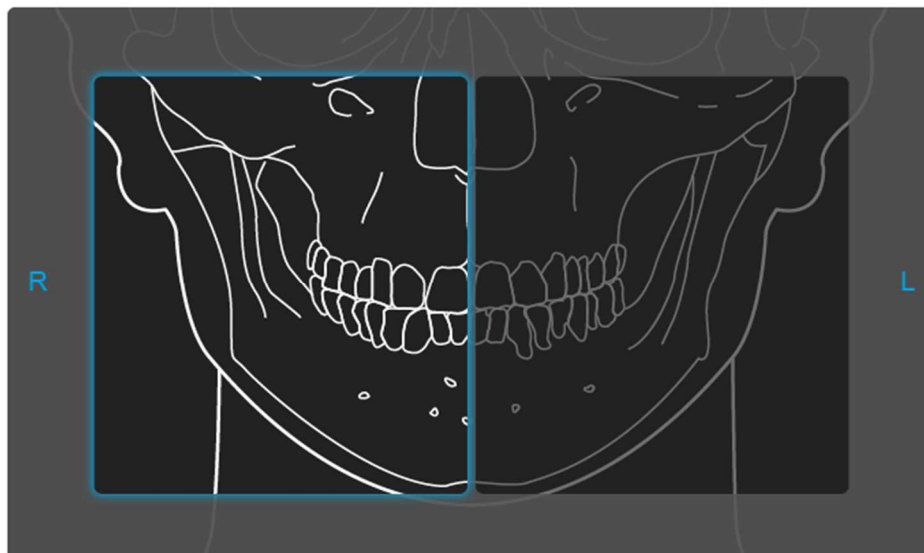

Figure 15: Half Panoramic Right selection

The following selections are possible for the Bitewing exam range:
 < Single - Bilateral >

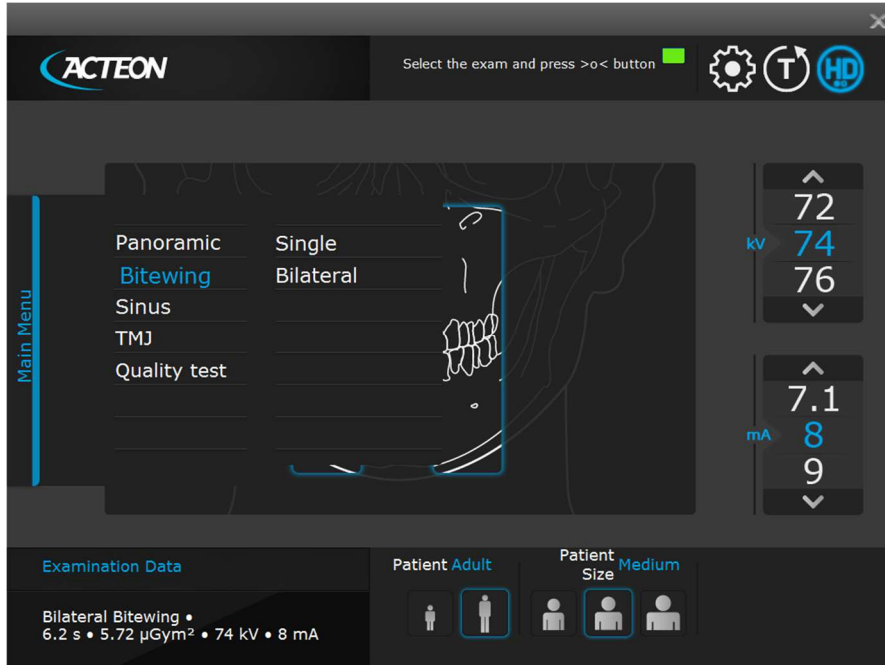

Figure 16: Bitewing exam range

Selecting "Single" are possible the following exam options:

< R (Right) - L (Left) >

The selection is done clicking on the corresponding side of the image

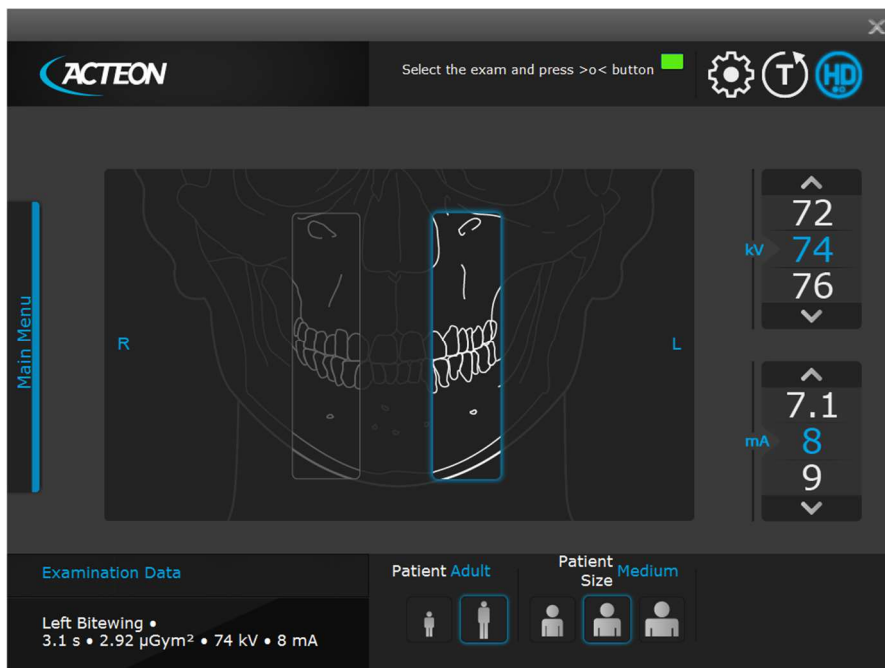

Figure 17: Right Bitewing selection



Note

The new X-MIND prime is based on a standard dentition and ascending rami shape. This shape, based on statistical studies, establishes a form for the dentomaxillofacial complex, adopted as "standard". X-MIND prime follows a rototranslation path which maintains the magnification factor as stated in the Technical Characteristics of each type of exam as constant along this "standard" shape and in the dentition area. The patient's anatomy can differ significantly from the statistical model, so the magnification factor is not maintained and can be different from the value stated. Based on his experience and competence, the user has to judge this variation.

IN ANY CASE, RADIOGRAPHY IMAGES CANNOT BE USED TO PERFORM CALCULATIONS OF DISTANCES, ANGLES ETC. ON THE IMAGE.



Warning

The measurement of lengths on digital images depends on the specific length calibration of the programme used.

It is therefore very important to check the length calibration of the programme. With panoramic exams, to obtain the measurement of the anatomical part, taking into consideration the enlargement factor, the length calibration factor is 100 pixels = 7.8 mm (in the centre of the focus layer).

8.8.2.1 Left / Right Half Panoramic

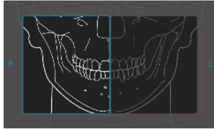

The Half Panoramic mode, right or left, means that only the corresponding half arch is irradiated; emission will start from the beginning, to just after the mid sagittal plane for the right part. For the left, it will start just before the mid sagittal plane and continue until the end of the rotation.

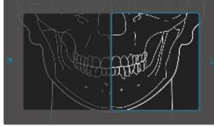

These two kinds of exams are normally used when it is already known that the patient has a problem on only one half of the arch, so it is possible to reduce patient irradiation. Follow the instructions for normal panoramic exams for patient positioning.

8.8.2.2 Frontal dentition

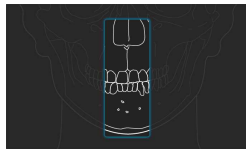

The Frontal dentition exam takes an X-ray of the frontal dentition area (roughly from canine to canine). Follow the instructions for normal panoramic exams for patient positioning.

8.8.2.3 Low dose Panoramic



The low dose panoramic exam takes an X-ray only of the dental arch, excluding the ascending rami of the temporo-mandibular joint from the image; the exam is performed with the same trajectory of the standard Panoramic exam, reducing the rays' emission time.

This exam is used, for instance, during treatment continuation phases or where a lack of pathologies of the same joint is already known.

Follow the instructions for normal panoramic exams for patient positioning.

8.8.2.4 Ortho Rad dentition



The ortho rad panoramic exam delivers an image of the pure dental arch, excluding the ascending rami branches of the temporo-mandibular joint from the image; the trajectory of the rotating arms is, however, optimised for a better orthogonality between the X-ray beam and incident sections of near teeth. Thus the image has reduced teeth overlapping, improving the diagnosis of interproximal decay.

As a consequence of the different trajectory, the focus layer, mainly in the front teeth area, is smaller and patient positioning for this exam needs more care. Follow the instructions for normal panoramic exams for patient positioning.

8.8.2.5 Single Bitewing

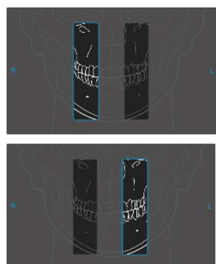

The Single Bitewing mode, either right or left, means that only the corresponding dentition sector is irradiated; for the Right side the emission will start from the beginning, to just after the mid sagittal plane for the right part. For the left, it will start just before the mid sagittal plane and continue until the end of the rotation. The exam is performed with the same trajectory of the Ortho Rad Panoramic exam, reducing the rays' emission time to include just molar and pre-molar teeth.

This exam is normally used when it is already known that the patient has a problem on one side of the bite-sectors of the arch, so it is possible to reduce patient irradiation.

Follow the instructions for normal panoramic for patient positioning.

8.8.2.6 Bilateral Bitewing

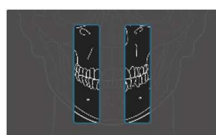

The bilateral Bitewing mode, right and left, means that the two bite-sectors are irradiated; the exam is performed with the same trajectory of the standard panoramic exam, reducing the rays' emission time.

This exam is normally used when it is already known that the patient has a problem on the bite-sectors of the arch, so it is possible to reduce patient irradiation.

Follow the instructions for normal panoramic for patient positioning.

8.8.3 Preparation of the patient



Note

These positioning instructions are valid both for adult and paediatric patients.



Note

If the unit is installed according to suggested height (see paragraph 6.1), the chinrest height when the column is in its lower position is at 97.5 cm (38.4") from the floor, as a consequence, unit can be used with patient at least 118 cm (3 ft 10.4") high.

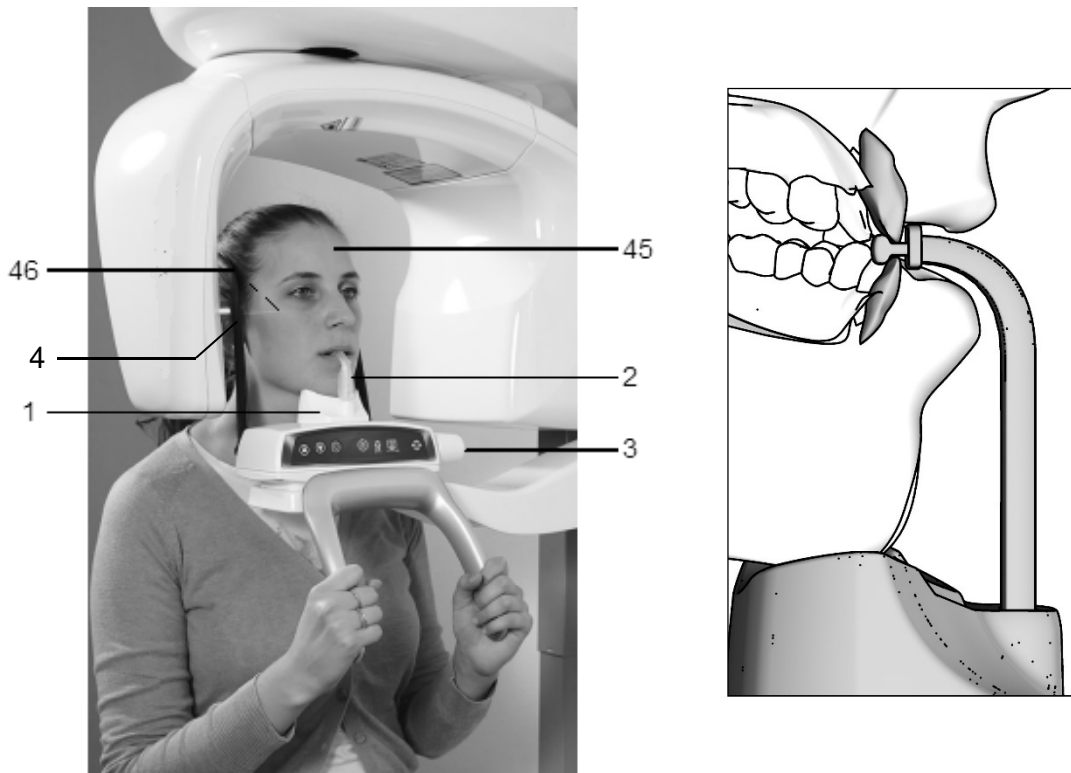

Label	Description
45	Sagittal medial line
46	Frankfurt line
1	Panoramic chin rest
2	Centring bite
3	Temple claps closing/release knob
4	Laser Knob

Figure 18: Patient positioning

1. Ask the patient to remove all metallic objects located in the area to be X-rayed (necklaces, earrings, glasses, hairpins, removable dental prosthesis, etc.). Ensure there are no thick garments in the area to be X-rayed (coats, jackets, ties, etc.).
2. Ask the patient to put on the protective apron, or something similar, making sure it does not interfere with the trajectory of the X-ray beams.
3. Place the patient in a standing position at the Panoramic chin rest. With the "Column movement" keys (1 - Figure 10), raise/lower the column until the chin support is aligned with the patient's chin.

**Warning**

During the patient positioning, make sure the equipment cannot collide with any object in the room.

4. Position the patient with the temple clasps ensuring that the chin is positioned on the dedicated support; the hands should rest on the front handles. Ask the patient to bite the reference notch of the bite with his incisors (Figure 18). In the case of edentulous patients, he/she must rest the chin against the reference shoulder of the edentulous chin support.
5. Tell the patient to close his eyes.
6. Press the "Luminous centring devices" key (2 - Figure 10). Two laser beams will light up the sagittal medial plane line and the horizontal line for the Frankfurt plane reference (the plane that identifies a line that ideally links the ear hole - the auditory meatus - with the lower part of the orbital fossa). Position the patient's head in such a way as to ensure that the luminous beams fall in correspondence with respective anatomical references (Figure 18). The luminous beam of the Frankfurt plane can be adjusted according to the patient's height; this can be adjusted using the laser knob (4 - Figure 18).
7. At this point, the patient must move his feet towards the column, making sure he keeps his head within the pre-aligned anatomical references. This ensures a greater extension of the spine in the cervical area, improving the darkening of the X-ray in the apical area of the incisors, and avoiding the collision of the tube-head with the patient's shoulders. Check that the Frankfurt plane is still horizontal.

**Note**

The laser centring devices remain on for approximately 2 minute; shutdown can be anticipated by pressing the "Luminous centring device" key (2 - Figure 10) or, with alignment complete, by pressing the "Patient entrance" key (6 - Figure 10) to begin preparation for exposure.

8. Close the temple clasps to help the patient maintain a correct position.
9. Press the "Patient Entrance" (6 - Figure 10) key to confirm the parameters. The luminous centring devices switch off and the rotating arm goes to the exam start position. Once alignment has been completed, the green LED "Ready for X-ray" (3 - Figure 10) lights up to indicate that pressing the X-ray button once more will start the radiation phase.



10. Ask the patient to: keep their lips closed, move their tongue towards their palate, keep perfectly still and not look at the rotating arm during movement.

Note

With paediatric patient it is recommended to have a greater attention in taking exams. Useful information and a specific checklist can be found at the Image Gently website (www.imagegently.org).

In general with child and adolescent patients, before taking the exposure it is suggested to run the exam in test mode in such a way to show the young patient how the unit works and make them feel comfortable.

8.8.4 Taking an exposure

Warning



During the emission of X-rays, protection procedures for the operator and personnel in the area must comply with local regulations. In all cases, it is recommended that only the patient and operator are present in the room during the emission of X-rays. If the operator is not protected by suitable screens, he must stand at least 2 meters away from the emission of the rays (Figure 1).

Note



When the "Test" key is selected, the Test function is activated. In this condition, it is possible to make the unit carry out all movements made during the exam without emitting X-rays.

Test mode may also be useful when the equipment is used on child patients, to show them how the equipment works before running the exam. Once the cycle is completed, deactivate the "Test" function by pressing the key again.

1. Check once again that exposure data are correct. If not, correct them as described in paragraph 8.7.2; ensure that the equipment's indicator light "Ready for X-rays" (4 - Figure 10) comes on, press the X-ray button for the entire duration of the exposure, checking the simultaneous working of the "X-rays emission" indicator (both on the equipment keyboard and GUI) and the acoustic ray signal. The Digital Acquisition System will, in the meantime, process the image.



Figure 19

At the end of the acquisition, the GUI will be replaced by the acquired image.

**Note**

X-MIND prime assumes that the digital sensor is ready: if this is not the case, the blue light indicator of "Computer connection" status (5 - Figure 10) start blinking slowly.

Refer to the Digital Acquisition System Manual to correct the situation.

**Note**

The rotation of the arm and the emission of the X-rays will start with a delay of about 3 seconds from when the X-ray button is pressed. As the X-ray button is a "dead man's switch", it must be kept pressed down until the end of the exposure.

2. Once the exposure is completed, the system will rotate back. When it has completed this movement, free the patient from the positioning device.
-

**Note**

If the exam is in "Test" mode with the patient already in position, the patient must not be removed from the temple clasp group, to avoid having to reposition him. Press the "Patient Entrance" key (6 - Figure 10) to return the unit to its initial position. Now the system is ready to perform a new exam.

3. Press the "Patient Entrance" key (6 - Figure 10), the unit will move back to the starting position
-

**Note**

If you try to perform a new exam, before the cooling period has ended, a message indicating the time to wait before performing a new exam will be displayed.

The waiting time allows the anode in the radiogenic tube to cool down.

**Warning**

After each exam, clean the chin support, the handles and the temple clasps group thoroughly and change the disposable bite protective sleeve.

**Note**

During panoramic exams, the value of the exposure parameters varies according to a fixed curve, to compensate for variations in absorption by the patient's tissues. In this way, it is possible to obtain a good uniformity of the image contrast. In particular, the chosen value of the kV is lowered in the initial and end sections of the panoramic exam and increased in the incisors/canine zone.

The tube current varies according to the kV, also if the set value is slightly increased on the initial/end sections. These variations have the effect of compensating for greater X-ray absorption in the spinal column area. As an example, the variation of the parameters follows the curve below:

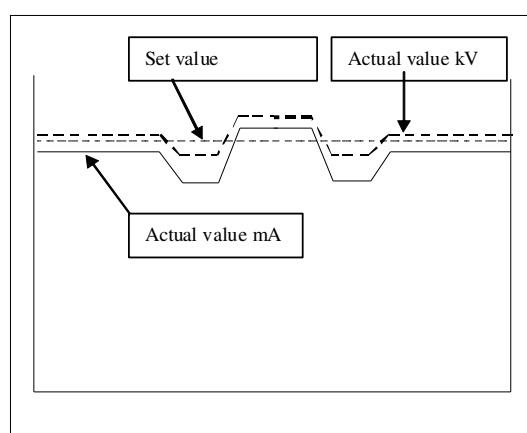

The values displayed during the panoramic exam correspond to the ones chosen by the user, while the real value in the various positions of the X-ray cycle can be different; in any case, the system guarantees that the accuracy of the exposure parameters is always within the limits set by IEC 60601-1 international standards for the safety of medical devices. In particular, in accordance with IEC 60601-2-63, the maximum deviation (including the correction according to the above curve and instrumental doubt) is within $\pm 10\%$ for the kV, while for the tube current it is within $\pm 15\%$.

8.8.5 Image processing windows

The Image Processing menu, if activated, will be displayed at the end of the acquisition in order to customize the default image post-processing settings. The feature can be either enabled or disabled through the corresponding option available under Settings.

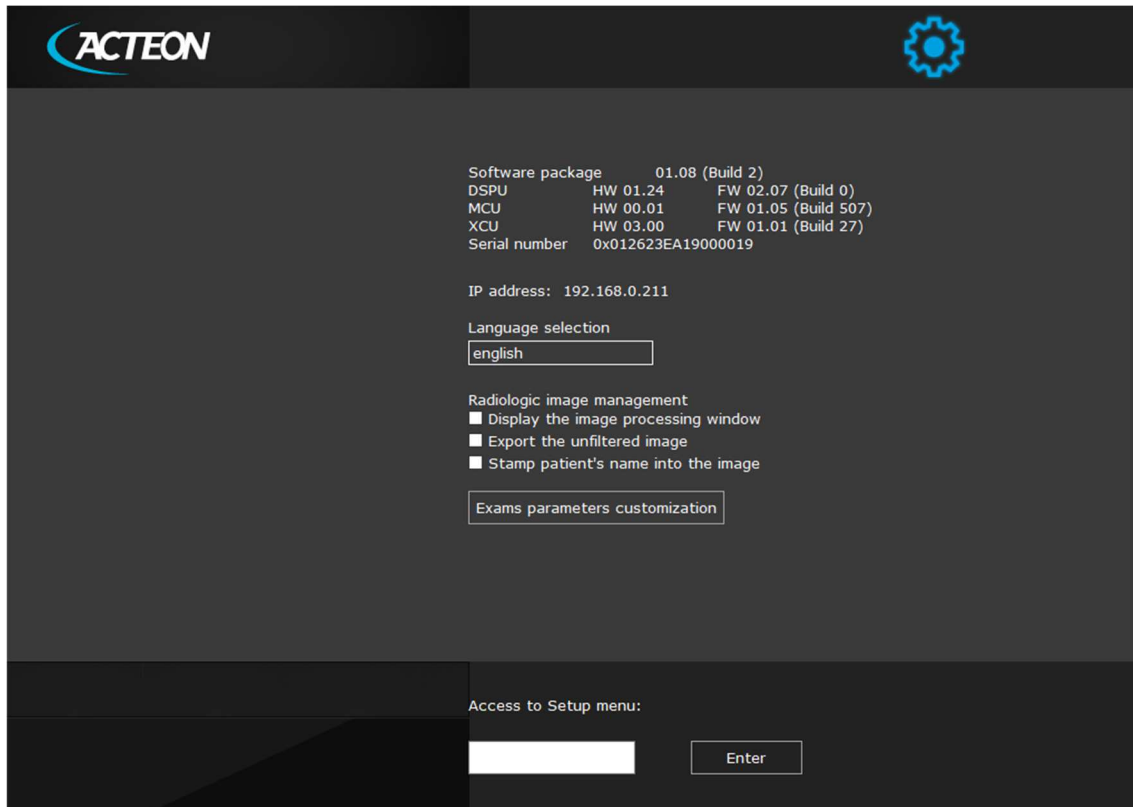

Figure 20

The Image Processing window is composed by three main area (Figure 21):

1. Filters area
2. Toolbars area allowing the filter customization
3. Image preview area displaying the current post-processing.

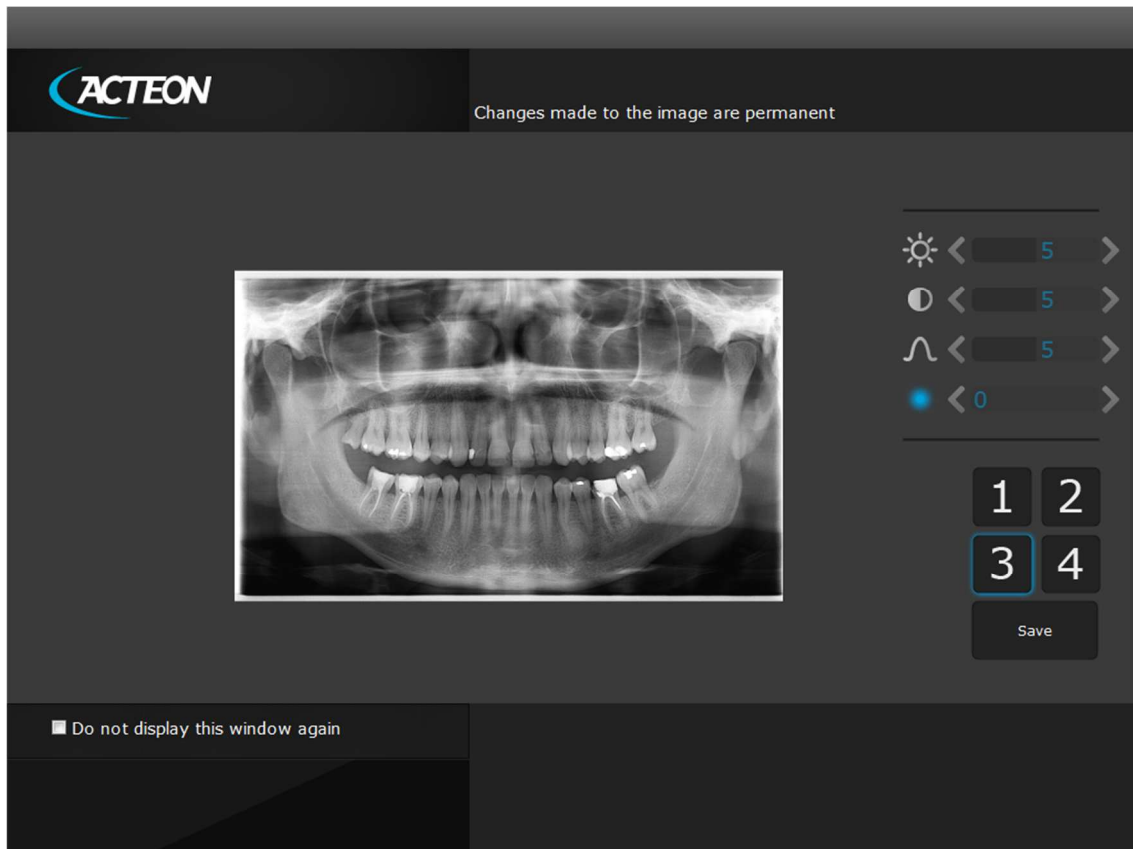

Figure 21

Buttons from 1 to 3 implement pre-set filters. Clicking the button, the corresponding filter will be applied and the preview displayed. The default post-processing can be modified through dedicated toolbars, from the top respectively:

- brightness
- contrast
- gamma value
- image enhancement.

The button Save will apply the current setting to the corresponding button and will set the filter as default in acquisition (Figure 22).
The button 4 is set as default to load the original image (without post-processing) and it can be fully customized as above described.

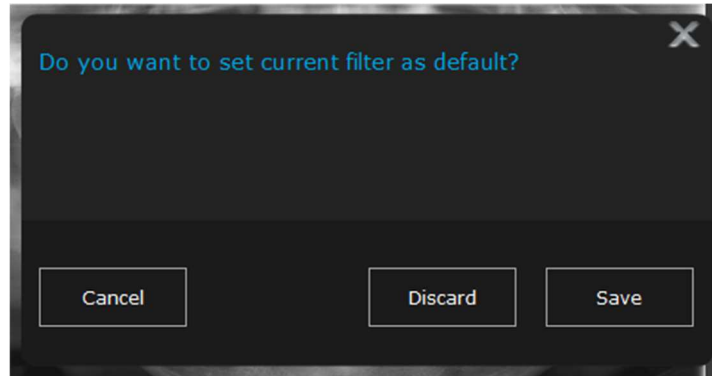

Figure 22

8.9 Sinus exam

On the Virtual Interface select: *Main Menu > Sinus*
Exam information and graphics will be loaded accordingly.

The system is positioned with the following configuration:

- ADULT with the display of the corresponding graphic for the key
- MEDIUM SIZE with the display of the corresponding graphic for the key
- default exposure parameters (if this is the first SINUS exposure), or the exposure parameters (kV and mA) of the last exposure performed.

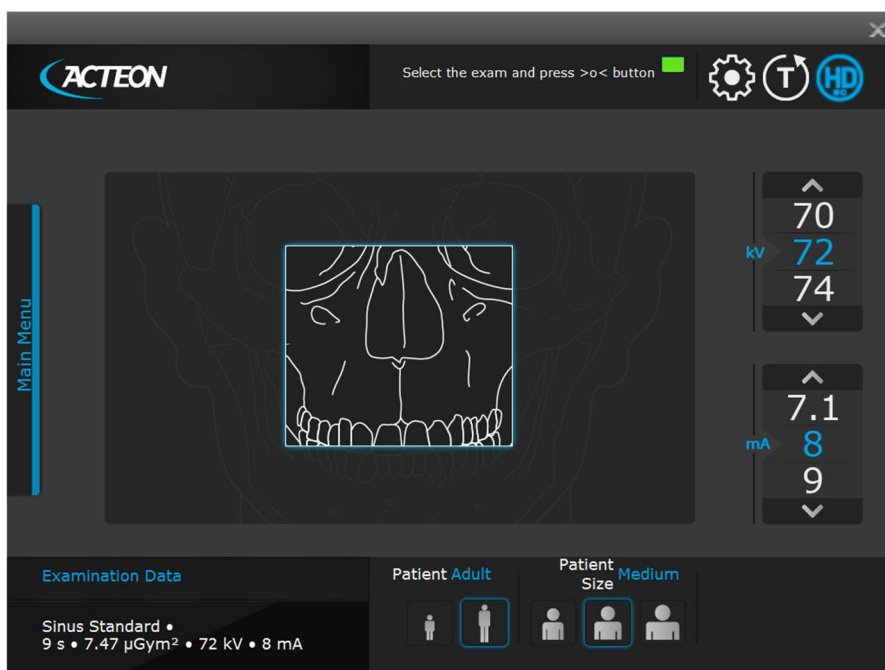

Figure 23

Select the type of patient with the Patient icons (Adult - Child).
Select the type of build with the Patient Size icons (Small - Medium - Large).
On the basis of the selections made, the display will visualize the kV and mA settings as in the table:

Exposure values in SINUS mode				
	Adult Patient (9.4 seconds)		Child Patient (9.4 seconds)	
	kV	mA	kV	mA
Small	64	5.6	64	4.5
Medium	66	5.6	66	4.5
Large	68	5.6	68	4.5

**Note**

The exam parameters set as the default are values to be taken as the starting point. Users can optimise the parameters according to their needs.

Once the settings have been completed, the chin support must be placed in position.

**Note**

X-MIND prime is based on a standard dentition and ascending rami shape. This shape, based on statistical data, establishes a standard shape for the dentomaxillofacial complex, also defining the position and the direction of the condyles. Patient anatomy can differ significantly from the statistical model; based on experience and competence, the user has to judge this variation. **IN ANY CASE, RADIOGRAPHY IMAGES CANNOT BE USED TO PERFORM CALCULATIONS OF DISTANCES, ANGLES ETC. ON THE IMAGE.**

**Warning**

The measurement of lengths on digital images depends on the specific length calibration of the programme used. It is therefore very important to check the length calibration of the programme. With SINUS exams, to obtain the measurement of the anatomical part, taking into consideration the enlargement factor, the length calibration factor is 100 pixels = 7.9 mm (in the centre of the focus layer).

8.9.1 Preparation of the patient



Note

These positioning instructions are valid both for adult and paediatric patients.



Note

If the unit is installed according to suggested height (see paragraph 6.1), the chinrest height when the column is in its lower position is at 97.5 cm (38.4") from the floor, as a consequence, unit can be used with patient at least 118 cm (3 ft 10.4") high.

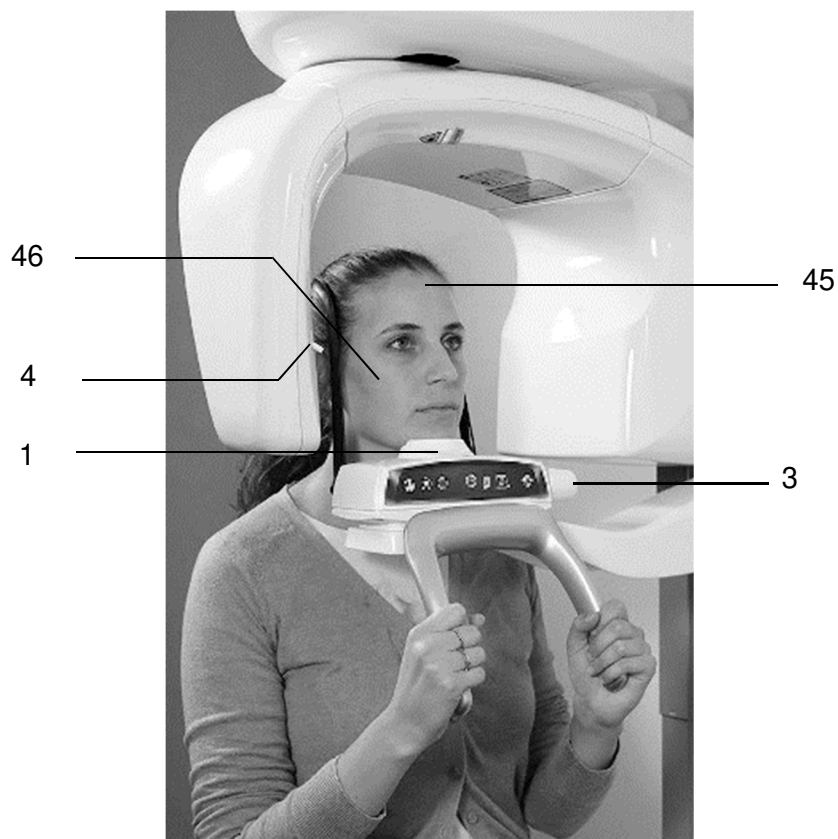

Label	Description
45	Sagittal medial line
46	Frankfurt line
1	Sinus positioner
3	Temple claps closing/release knob
4	Laser knob

Figure 24: SINUS positioning

1. Ask the patient to remove all metallic objects located in the area to be X-rayed (necklaces, earrings, glasses, hairpins, removable dental prosthesis, etc.). Ensure that there are no thick garments in the area to be X-rayed (coats, jackets, ties, etc.).
2. Ask the patient to put on the protective apron, or something similar, making sure it does not interfere with the trajectory of the X-ray beams.
3. Place the patient in a standing position at the SINUS chin support. With the "Column movement" keys (1/2 - Figure 10), raise/lower the column until the chin support is aligned with the patient's chin.

**Warning**

During the patient positioning, make sure the equipment cannot collide with any object in the room.

4. Position the patient with the temple clasps ensuring that the chin is positioned on the dedicated support; ask the patient to place his hands on the front supports.
5. Instruct the patient to close his eyes.
6. Press the "Luminous centring devices" key (2 - Figure 10). Two laser beams will light up the sagittal medial plane line and the horizontal line for the Frankfurt plane reference (the plane that identifies a line that ideally links the ear hole - the auditory meatus - with the lower part of the orbital fossa). Position the patient's head in such a way as to ensure that the first two luminous beams fall in correspondence with respective anatomical references (Figure 24).
The luminous beam of the Frankfurt plane can be adjusted according to the patient's height; this can be adjusted by means of the laser knob (4 - Figure 24).

**Note**

The laser centring devices remain on for approximately 2 minute; shutdown can be anticipated by pressing the "Luminous centring device" key (2 - Figure 10) or, with alignment complete, by pressing the "Patient entrance" key (6 - Figure 10) to begin preparation for exposure.

7. Close the temple clasps; this will help the patient to stay in a correct position. Check that, during this phase, the patient has not changed position.
8. Press the "Patient Entrance" (6 - Figure 10) key to confirm the parameters. The luminous centring devices switch off and the rotating arm goes to the exam start position. Once alignment has been completed, the green LED "Ready for X-ray" (3 - Figure 10) lights up to indicate that pressing the X-ray button once more will start the radiation phase.
9. Ask the patient to: close his mouth, keep perfectly still and not look at the rotating arm during movement.

**Note**

With paediatric patient it is recommended to have a greater attention in taking exams. Useful information and a specific checklist can be found at the Image Gently website (www.imagegently.org).

In general with child and adolescent patients, before taking the exposure it is suggested to run the exam in test mode in such a way to show the young patient how the unit works and make them feel comfortable.

8.9.2 Taking an exposure



Warning

During the emission of X-rays, protection procedures for the operator and personnel in the area must comply with local regulations. In all cases, it is recommended that only the patient and operator are present in the room during the emission of X-rays. If the operator is not protected by suitable screens, he must stand at least 2 meters away from the emission of the rays (Figure 1).



Note

Before performing a Sinus exam, because of the specific trajectory described by the rotating arm, it is recommended to check for possible mechanical interference with the patient's shoulder during rotation. Press the "Test" icon to activate the Test function. In this condition, it is possible to make the unit carry out all movements made during the exam without emitting X-rays. Test mode may also be useful when the equipment is used on child patients, to show them how the equipment works before running the exam.

Once the cycle is completed, deactivate the "Test" function by pressing the icon again.

1. Check once again that exposure data are correct. If not, correct them as described in paragraph 8.7.2; ensure that the equipment's indicator light "Ready for X-rays" (4 - Figure 10) comes on, press the X-ray button for the entire duration of the exposure, checking the simultaneous working of the "X-rays emission" indicator (both on the equipment keyboard and GUI) and the acoustic ray signal.
The Digital Acquisition System will, in the meantime, process the image.
At the end of the acquisition, the GUI will be replaced by the acquired image.



Note

During the exam, one single rotation of the rotating arm is to be expected, with X-ray emission limited to the area concerned.



Note

X-MIND prime assumes that the digital sensor is ready: if this is not the case, the blue light indicator of "Computer connection" status (5 - Figure 10) start blinking slowly.

Refer to the Digital Acquisition System Manual to correct the situation.



Note

The rotation of the arm and the emission of the X-rays will start with a delay of about 3 seconds from when the X-ray button is pressed. As the X-ray button is a "dead man's switch", it must be kept pressed down until the end of the exposure. The X-ray emission to the central part of the dental arch is suspended during the X-ray phase, so the relative signals (sound and visual) are therefore also suspended.

2. Once the exposure is completed, the system will rotate back. When it has completed this movement, free the patient from the positioning device.

Note

If the exam is in "Test" mode with the patient already in position, the patient must not be removed from the temple clasp group, to avoid having to reposition him. Press the "Patient Entrance" key (6 - Figure 10) to return the unit to its initial position. Now the system is ready to perform a new exam.

3. Press the "Patient Entrance" key (6 - Figure 10), the unit will move back to the starting position.

Note

If you try to perform a new exam, before the cooling period has ended, a message indicating the time to wait before performing a new exam will be displayed.
The waiting time allows the anode in the X-ray tube to cool down.



Warning

After each exam, clean the chin support, the handles and the temple clasps group thoroughly and change the disposable bite protective sleeve.

4. Follow instruction on paragraph 8.8.5 to perform image processing function.

8.10 TMJ exam

The TMJ exam with open/closed mouth is similar to panoramic exams; the only difference is that exposure is only on the TMJ (Temporo Mandibular Joint) area. The operating sequence of the exam is therefore identical to that described for panoramic exams.

The temporo-mandibular joint exam uses projection geometry giving an image of the X-rayed condyle along a direction almost parallel with its major axis, in order to achieve a clear view of its positioning inside the cavity.

The TMJ Standard function makes it possible to obtain 4 different acquisitions on the same image, by performing two rotational movements. The 4 images represent the right and left condyle of the temporo-mandibular arch (TMJ) with closed mouth and open mouth.

Figure 25 shows the information related to the single sectors.

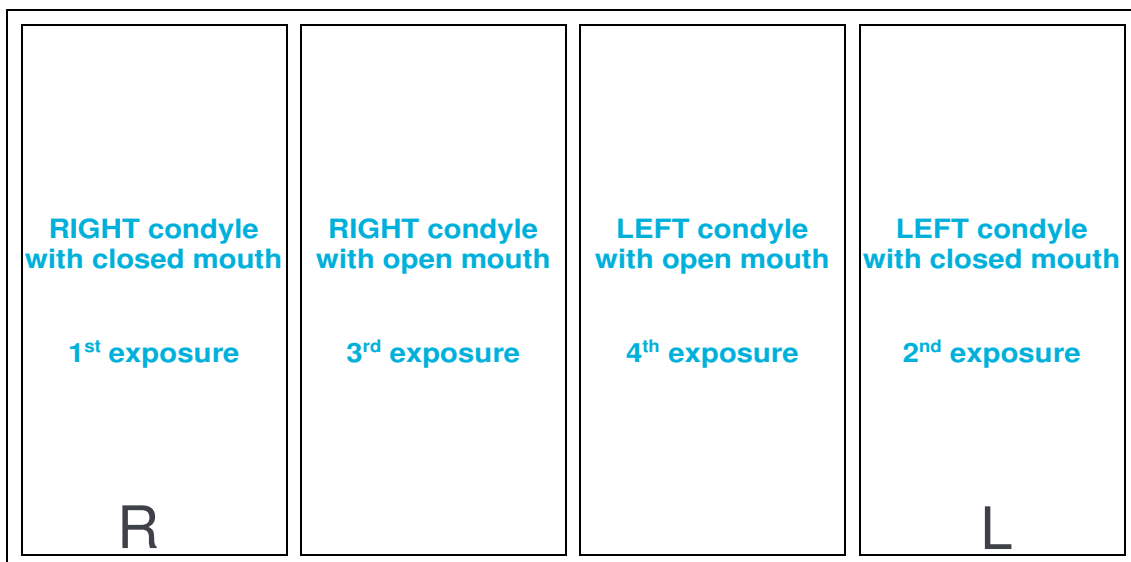

Figure 25: TMJ Standard

In TMJ Single Phase function it is possible to obtain 2 different acquisitions that represent the right and left condyle with closed mouth or open mouth.

Figure 26 shows the information related to the single sectors.

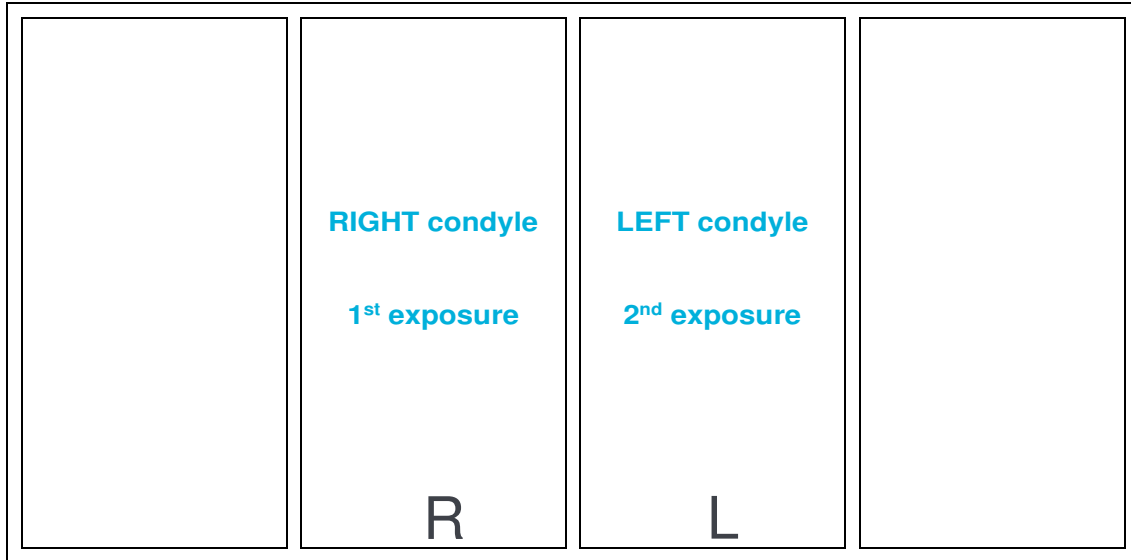

Figure 26: TMJ Single Phase

Note



During the TMJ exam, the emission of X-rays is intermittent (it is interrupted during the transition phases between various exposures), but it is necessary to keep the X-ray button pressed for the entire rotation time. Do not release the X-ray button during emission interruption, unless necessary. The cooling phase of the tube-head occurs at the end of the exposures. In the CHILD position, the start of exposure is delayed by a few degrees compared to the ADULT position.

8.10.1 Preparation of the device

On the Virtual Interface select: *Main Menu > TMJ > Standard* for TMJ Open/Closed mouth (4 exposure) or *Main Menu > TMJ > Single Phase* for TMJ Open or Closed mouth (2 exposure).

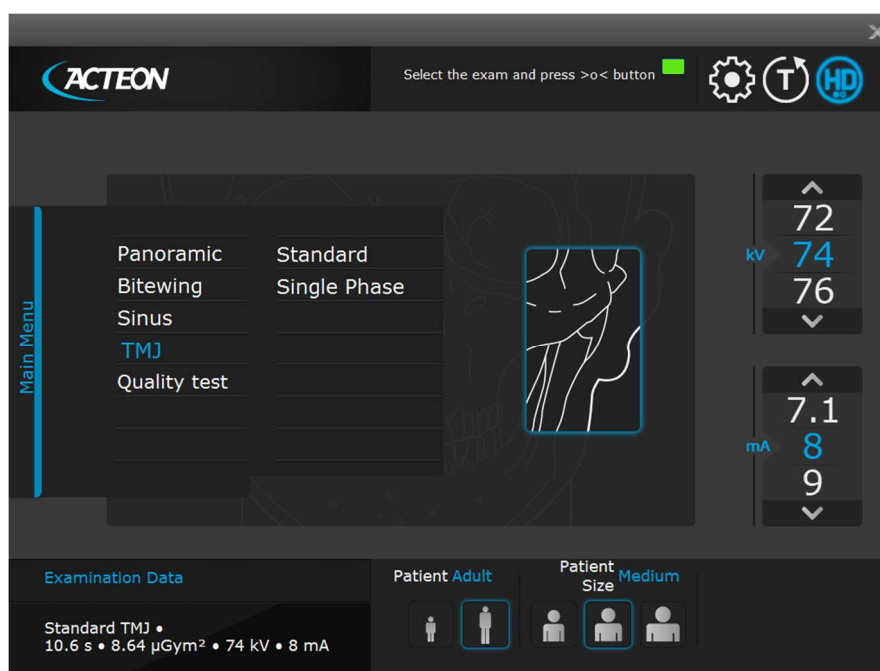

Figure 27

The exam information and graphics will be loaded accordingly.

The system is positioned with the following configuration:

- ADULT with the display of the corresponding graphic for the key
- MEDIUM SIZE with the display of the corresponding graphic for the key
- default exposure parameters (if this is the first TMJ exposure), or the exposure parameters (kV and mA) of the last exposure performed.

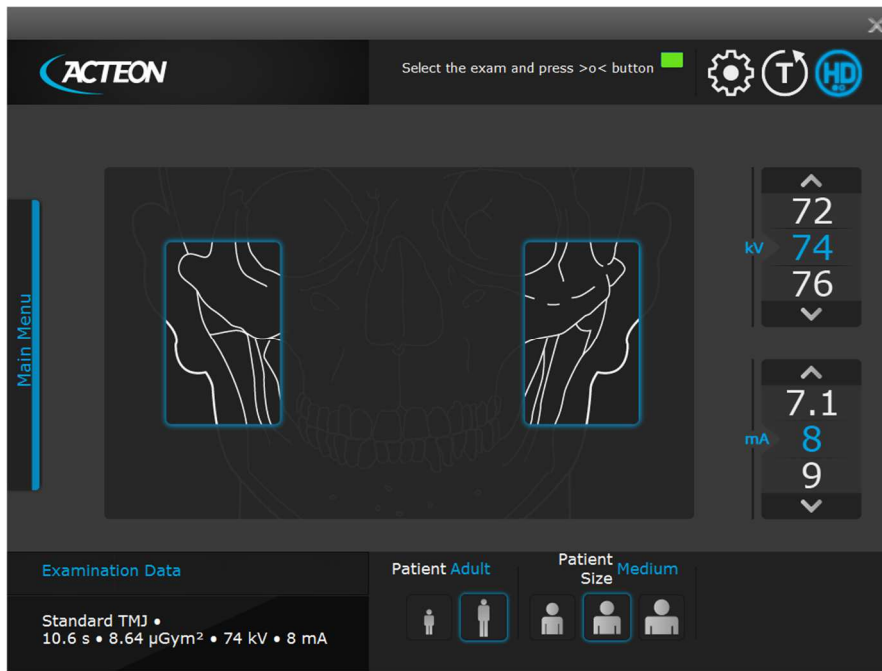

Figure 28

Select the type of patient with the Patient icons (Adult - Child).
 Select the type of build with the Patient Size icons (Small - Medium - Large).
 On the basis of the selections made, the display will show the kV and mA settings, as in the table:

Exposure values in TMJ mode				
	Adult Patient (9,7 seconds)		Child Patient (9,7 seconds)	
	kV	mA	kV	mA
Small	64	5.6	64	4.5
Medium	66	5.6	66	4.5
Large	68	5.6	68	4.5



Note

The exam parameters set as the default are values to be taken as the starting point. Users can optimise the parameters according to their needs.

Once the settings have been completed, the chin support must be placed in position.



Note

X-MIND prime is based on a standard dentition and ascending rami shape. This shape, based on statistical data, establishes a standard shape for the dentomaxillofacial complex, also defining the position and the direction of the condyles. Patient anatomy can differ significantly from the statistical model; based on experience and competence, the user has to judge this variation.

IN ANY CASE, RADIOGRAPHY IMAGES CANNOT BE USED TO PERFORM CALCULATIONS OF DISTANCES, ANGLES ETC. ON THE IMAGE.



Warning

The measurement of lengths on digital images depends on the specific length calibration of the software used. It is therefore very important to check the length calibration of the software. With TMJ exams, to obtain the measurement of the anatomical part, taking into consideration the enlargement factor, the length calibration factor is 100 pixels = 8 mm (in the centre of the focus layer).

8.10.2 TMJ closed mouth: preparation of the patient



Note

These positioning instructions are valid both for adult and paediatric patients.



Note

If the unit is installed according to suggested height (see paragraph 6.1), the chinrest height when the column is in its lower position is at 97.5 cm (38.4") from the floor, as a consequence, unit can be used with patient at least 118 cm (3 ft 10.4") high.

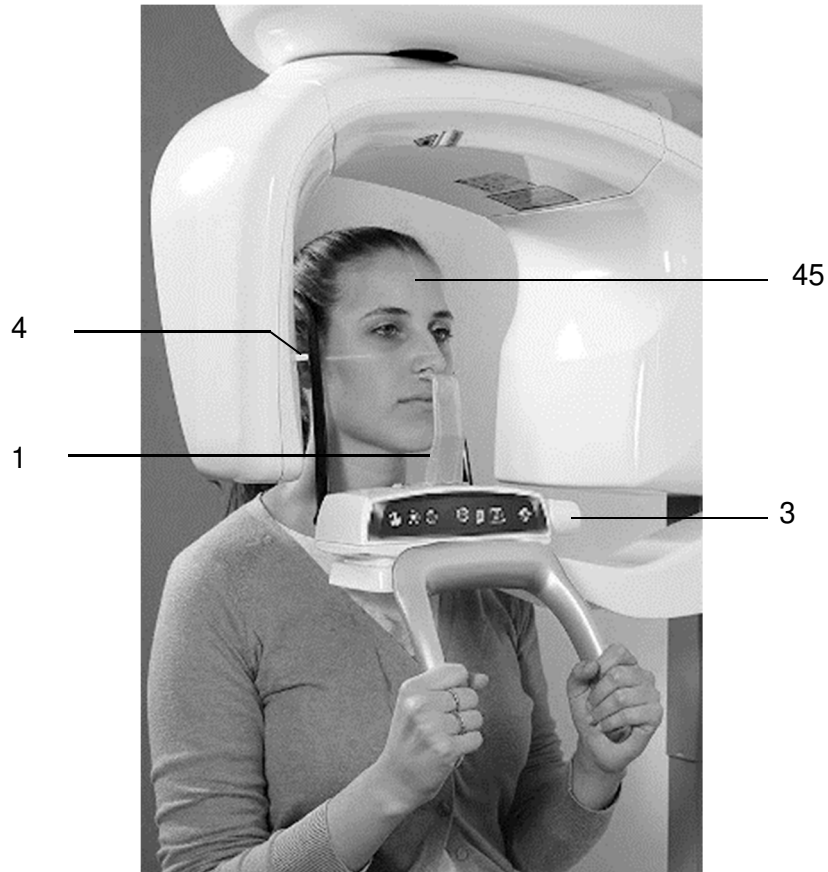

Label	Description
45	Sagittal medial line
1	TMJ positioner
3	Temple claps closing/release knob
4	Laser knob

Figure 29 – TMJ closed mouth positioning

1. Ask the patient to remove all metallic objects located in the area to be X-rayed (necklaces, earrings, glasses, hairpins, removable dental prosthesis, etc.). Ensure that there are no thick garments in the area to be X-rayed (coats, jackets, ties, etc.).
2. Ask the patient to put on the protective apron, or something similar, making sure it does not interfere with the trajectory of the X-ray beams.
3. Place the patient in a standing position at the TMJ positioner. With the "Column movement" keys (1/2 - Figure 10), raise/lower the column until the TMJ positioner is aligned with the patient's nose.

**Warning**

During the patient positioning, make sure the equipment cannot collide with any object in the room.

4. Position the patient with the temple clasps (asking him to place his hands on the front support).
5. Instruct the patient to close his eyes.
6. Press the "Luminous centring devices" key (2 - Figure 10). Two laser beams will light up the sagittal medial plane line and the horizontal line for the Frankfurt plane reference (the plane that identifies a line that ideally links the ear hole - the auditory meatus - with the lower part of the orbital fossa). Using the sagittal medial plane laser (45 - Figure 29) as the reference, position the patient's head in such a way that the sagittal medial plane is lit by the corresponding laser beam. The reference of the Frankfurt plane can be used to make sure the head of the patient remains in the same position when the exam is taken with the mouth either open or closed.

Note

The laser centring devices remain on for approximately 2 minute; the shutdown can be anticipated by pressing the "Luminous centring devices" key (2 - Figure 10) or, with alignment complete, by pressing the "Patient entrance" key (6 - Figure 10) to begin preparation for exposure.

7. Close the temple clasps; this will help the patient to stay in a correct position. During this phase, check the patient has not changed position.
8. Press the "Patient Entrance" (6 - Figure 10) key to confirm the parameters. The luminous centring devices switch off and the rotating arm goes to the exam start position. Once alignment has been completed, the green LED "Ready for X-ray" (3 - Figure 10) lights up to indicate that pressing the X-ray button once more will start the radiation phase.
9. Ask the patient to: keep their lips closed, keep perfectly still and not look at the rotating arm during movement.

Note

With paediatric patient it is recommended to have a greater attention in taking exams. Useful information and a specific checklist can be found at the Image Gently website (www.imagegently.org).

In general with child and adolescent patients, before taking the exposure it is suggested to run the exam in test mode in such a way to show the young patient how the unit works and make them feel comfortable.

8.10.3 Carrying out the first exposure

Warning



During the X-rays emission, protection procedures for the operator and personnel in the area must comply with local regulations. In all cases, it is recommended that only the patient and operator are present in the room during the emission of X-rays. If the operator is not protected by suitable screens, he must stand at least 2 meters away from the emission of the rays (Figure 1).

Note



If considered necessary, interference of rotation movement with the patient's shoulder can be checked; the Test function can be activated by pressing the "T" key on the Virtual Interface. In this condition, it is possible to make the unit carry out all movements made during the exam without emitting X-rays. The test function of the TMJ closed/open mouth is the same as for the panoramic mode and so there will not be a second rotation corresponding to the open mouth exam. Test mode may also be useful when the equipment is used on child patients, to show them how the equipment works before running the exam. Once the cycle is completed, deactivate the "Test" function by pressing the "T" key again.

1. Check once again that exposure data are correct. If not, correct them as described in paragraph 8.7.2; ensure that the equipment's indicator light "Ready for X-rays" (4 - Figure 10) comes on, press the X-ray button for the entire duration of the exposure, checking the simultaneous working of the "X-rays emission" indicator (both on the equipment keyboard and GIU) and the acoustic ray signal.
The Digital Acquisition System will, in the meantime, process the image.
-

Note



X-MIND prime assumes that the digital sensor is ready: if this is not the case, the blue light indicator of "Computer connection" status (5 - Figure 10) start blinking slowly.
Refer to the Digital Acquisition System Manual to correct the situation.

Note



The rotation of the arm and the emission of the X-rays will start with a delay of about 3 seconds from when the X-ray button is pressed. Since the X-ray button is a "dead man's switch", it must be kept pressed until the end of the exposure. The X-ray emission to the central part of the dental arch is suspended during the X-ray phase, so relative signals (sound and visual) are also stopped.



2. Once the exposure is completed, the system will carry out a short return rotation and the message "Press >O< button" will be displayed.
It will then be possible to set up the system for an open mouth exam, keeping the patient in position, or release him from the operating area.
3. Press the "Patient Entrance" key (6 - Figure 10). The equipment will reposition itself in the starting position.
In TMJ Standard examination, at the end of the movement, the message "Instruct patient to open mouth" will be displayed.

8.10.4 TMJ open mouth: preparation of the patient



Note

These positioning instructions are valid both for adult and paediatric patients.



Note

If the unit is installed according to suggested height (see paragraph 6.1), the chinrest height when the column is in its lower position is at 97.5 cm (38.4") from the floor, as a consequence, unit can be used with patient at least 118 cm (3 ft 10.4") high.

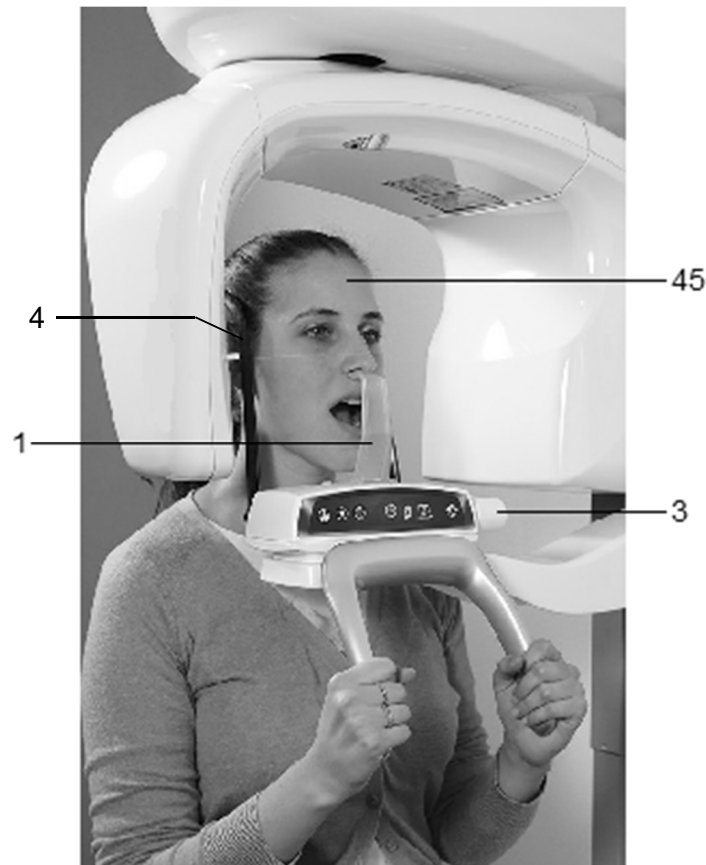

Label	Description
45	Sagittal medial line
1	TMJ positioner
3	Temple claps closing/release knob
4	Laser knob

Figure 30: TMJ open mouth positioning

1. If this is the first TMJ exposure, the patient has to be prepared following the operations described in paragraph 8.10.2.
2. Press the "Patient Entrance" key (6 - Figure 10).
3. Position the patient again if he has been removed from the centring device. Tell him to open his mouth (helping him to keep in position using appropriate mechanical devices - not supplied - if necessary).
4. Instruct the patient to close his eyes.
5. Press the "Luminous centring devices" key (2 - Figure 10). Two laser beams will light up the sagittal medial plane line and the horizontal line for the Frankfurt plane reference. Using the sagittal medial plane laser (45 - Figure 30) as the reference, position the patient's head in such a way that the sagittal medial plane is lit by the corresponding laser beam. The reference of the Frankfurt plane can be used to make sure the head of the patient stays in the same position when the exam is taken with the mouth either open or closed. If necessary, using the "Column movement" (1/2 - Figure 10) keys, lower the column slightly to compensate for the fact that the head, when opening the mouth, will be positioned behind and the condilus cannot be centred on the exposed area.

Note

The laser centring devices remain on for approximately 2 minute; shutdown can be anticipated by pressing the "Luminous centring device" key (2 - Figure 10) or, with alignment complete, by pressing the "Patient entrance" key (6 - Figure 10) to begin preparation for exposure.

6. Close the temple clasps; this will help the patient to stay in a correct position. Check that, during this phase, the patient has not changed position.
7. Advise the patient to keep perfectly still and not look at the rotating arm during movement.

Note

With paediatric patient it is recommended to have a greater attention in taking exams. Useful information and a specific checklist can be found at the Image Gently website (www.imagegently.org).
In general with child and adolescent patients, before taking the exposure it is suggested to run the exam in test mode in such a way to show the young patient how the unit works and make them feel comfortable.

8.10.5 Carrying out the second exposure



Warning

During X-rays emission, protection procedures for the operator and personnel in the area must comply with local regulations. In all cases, it is recommended that only the patient and operator are present in the room during the emission of X-rays. If the operator is not protected by suitable screens, he must stand at least 2 meters away from the emission of the rays (Figure 1).



Warning

Using the laser centring devices, check that the system is still aligned with the patient's sagittal medial plane.

1. Ensure that the equipment's indicator light "Ready for X-rays" (4 - Figure 10) comes on, press the X-ray button for the entire duration of the exposure, checking the simultaneous working of the "X-rays emission" indicator (both on the equipment keyboard and GUI) and the acoustic ray signal.
The Digital Acquisition System will, in the meantime, process the image.
At the end of the acquisition, the GUI will be replaced by the acquired image.



Note

X-MIND prime assumes that the digital sensor is ready: if this is not the case, the blue light indicator of "Computer connection" status (5 - Figure 10) start blinking slowly.
Refer to the Digital Acquisition System Manual to correct the situation.



Note

The rotation of the arm and the emission of the X-rays will start with a delay of about 3 seconds from when the X-ray button is pressed. As the X-ray button is a "dead man's switch", it must be kept pressed down until the end of the exposure. During the X-ray, the emission of rays in correspondence with the central part of the dental arch is suspended; the relative signals (acoustic and visual) are also suspended.

2. Once the exposure is completed, the system will rotate back. When it has completed this movement, free the patient from the positioning device.
3. Press the "Patient Entrance" key (6 - Figure 10). The equipment will reposition itself in the starting position.







Warning

After each exam, clean the TMJ positioner, the handles and the temple clasps group thoroughly and change the protective sleeve if used.





4. Follow instruction on paragraph 8.8.5 to perform image processing function.

8.11 Table of pre-set anatomic parameters





PANORAMIC

	Adult 	Child 
Small 	64 kV 5.6 mA	64 kV 4.5 mA
Medium 	66 kV 5.6 mA	66 kV 4.5 mA
Large 	68 kV 5.6 mA	68 kV 4.5 mA





BITEWING

	Adult 	Child 
Small 	64 kV 5.6 mA	64 kV 4.5 mA
Medium 	66 kV 5.6 mA	66 kV 4.5 mA
Large 	68 kV 5.6 mA	68 kV 4.5 mA

SINUS

	Adult 	Child 
Small 	64 kV 5.6 mA	64 kV 4.5 mA
Medium 	66 kV 5.6 mA	66 kV 4.5 mA
Large 	68 kV 5.6 mA	68 kV 4.5 mA

TMJ Open/Closed mouth

	Adult 	Child 
Small 	64 kV 5.6 mA	64 kV 4.5 mA
Medium 	66 KV 5.6 mA	66 kV 4.5 mA
Large 	68 KV 5.6 mA	68 kV 4.5 mA



Note

The exam parameters set as the default are values to be taken as the starting point. Users can optimise the parameters according to their needs.

9. ERROR MESSAGES

The error messages are divided into different areas that can be distinguished by the error number; the following table contains the different errors with meanings.

Main MCU board

Code	Error description
000 / 001	Internal MCU error
400 ÷ 411	MCU – DSPU communication fault (CAN Bus)

MCU EEPROM configuration

Code	Error description
100 / 101	Configuration area parameter doesn't match the expected one
102	Wrong version number in configuration area
103 / 104	Timeout error occurred during an EEPROM erase/write operation

Rotation Motor

Code	Error description
200	Zero position optical sensor of rotation axis always activated
201	Zero position optical sensor never activated
202 / 203	Zero position optical sensor of rotation still active after exiting from zero sensor
204	Unexpected activation of rotation optical sensor
205	Timeout on rotation

Y translation motor

Code	Error description
240	Zero position micro Y always active
241	Zero position micro Y never active
243	Timeout on Y axes

Disk collimator

Code	Error description
260	Collimator timeout on zero positioning

Hardware key board (U.I.C.)

Code	Error description
270 / 271	Hardware key fault

X-Ray Controls

Code	Error description
360	RX button pressed on start-up or before exam
362	RX button released during emission

Sensor Ready

Code	Error description
370	Sensor ready lost during exposure
371	Sensor not ready

Temperature sensor

Code	Error description
500 ÷ 503	Temperature sensor reading error

Generator Board

Code	Error description
750	Generator board initialization error
751	Alarm "overvoltage kV"
752	Alarm "overload on filament" on Generator board
753	Alarm "overload anodic current"
754	Alarm "filament not OK"
755	Alarm "backup timer"
756	Alarm "PFC not OK"
757	Alarm "Brown OUT"
758	Alarm "NO X-ray"
759	Alarm "unexpected emission"
760	Alarm "NO RX button command"
761	Alarm "NO X-ray emission"
762	Bad unit status: emission flag detected unexpectedly
763	kV analog feedback out of range
764	mA analog feedback out of range
765	Filament analog feedback out of range
766	Generator board reset due to a brown out
767	Generator board reset due to low voltage detection
768	Generator board reset due to a watchdog timeout
769	Generator board reset due to a stack overflow
770	Mismatch between generator board (A2) and MCU board (A1) types (2D / 3D)

Keyboard

Code	Error description
850	One or more keycodes are pressed
852	Button >0< pressed during movements

DSPU

Code	Error description
1003	DSPU hardware error detected
1004	MCU – DSPU communication error
1005	CAN Bus hardware error
1007	Sensor temperature too high

PC software user interface (GUI)

Code	Error description
1201	Setup menu: write data EEPROM failure
1202	Unexpected value detected by the software
1203	Software allocation failure
1204	Exposure parameters failure
1205	Image buffer allocation failure

PC driver interface (OSP / VSP)

Code	Error description
1401	Sensor frame lost during exam
1402	Sensor configuration failure
1403	Software watchdog error
1404	Sensor does not detect X-rays during exam

10. MAINTENANCE



Note

Maintenance and inspection procedure must be performed without patient positioned in the equipment.

This unit, like all other electrical appliances, must be used correctly and also serviced and controlled at regular intervals. This precaution ensures safe and efficient performance.

Regular maintenance consists of checks performed by the operator and/or by a qualified technician.

The operator can control the following items:

Frequency	Type of check	Method
Daily	Functioning of the indicator lights	Visual inspection
Daily	Check that the cables do not show signs of breaking or wear	Visual inspection
Daily	Check that the unit is not damaged externally in such a way that the safety of protection from radiation is compromised	Visual inspection
Daily	Check that there are no traces of oil on the tube-head	Visual inspection
Daily	Check that arm movement is smooth	Practical inspection
Monthly	Integrity of equipment and labels	Visual inspection



Warning

If the operator detects irregularities or failures, he must immediately call Technical Service.



Besides the above controls, the Service Engineer will also check the following during preventive maintenance:

Frequency	Type of check
Annually	Correct equipment centring (according to the Service Manual paragraph 9.3.2)
Annually	Check technical factors (according to paragraph 7.5)
Annually	Perform sensor calibration
Annually	Check that the fixing screws are tightened

11. PANORAMIC IMAGE ASSESSMENT

Panoramic radiography is an exam of the maxillo-facial region normally used to view the dental region inside the complete head and sinuses-orbital complex.

With a good panoramic exam, you can distinguish the main anatomic structures that are simplified in the diagram below (which indicates only the main ones and is not complete).

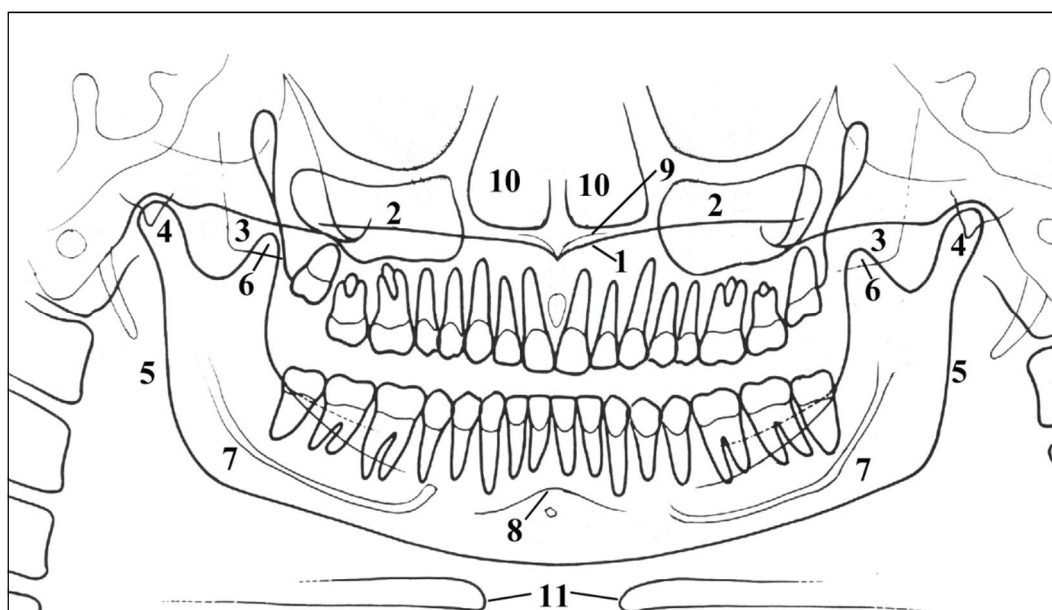

Figure 31

Ref	Anatomic structure
1	Palatal plane
2	Maxillary sinus
3	Maxilla and maxillary tuberosity
4	Temporo mandibular condyle
5	Ascending ramus of the TMJ
6	Coronoid process (overlap with maxilla)
7	Mandibular canal
8	Chin foramen
9	Anterior nasal spine
10	Nasal cavities
11	Ioid bone (normally duplicated)

11.1 Proper positioning of the patient

Patient positioning is determining to get good quality radiography. This is due to the fact that the shape of the focussed area, e.g. of the layer clearly shown on the image, tends to follow the dental arch and has a non-constant deepness. The objects outside this focused area will therefore appear blurred on the radiography.

1. The patient should not wear clothes that may interfere with the X-ray beams, also to leave more space between the patient's shoulders and the rotating arm of the equipment. Care must be taken in order to avoid interference between the X-ray beam and the protective apron worn by the patient.
2. Metal objects (necklaces, earrings etc.) must be avoided; these objects not only create radio-opaque images in their own position, but also false images projected in other parts of the radiography, so disturbing the correct view of the anatomy.
3. Patient's incisors must be positioned into the reference notch of the bite.
4. Frankfurt plane (plane passing through the inferior margin of the orbit and the upper margin of the ear canal) must be horizontal.
5. Mid-Sagittal plane must be centered and vertical.

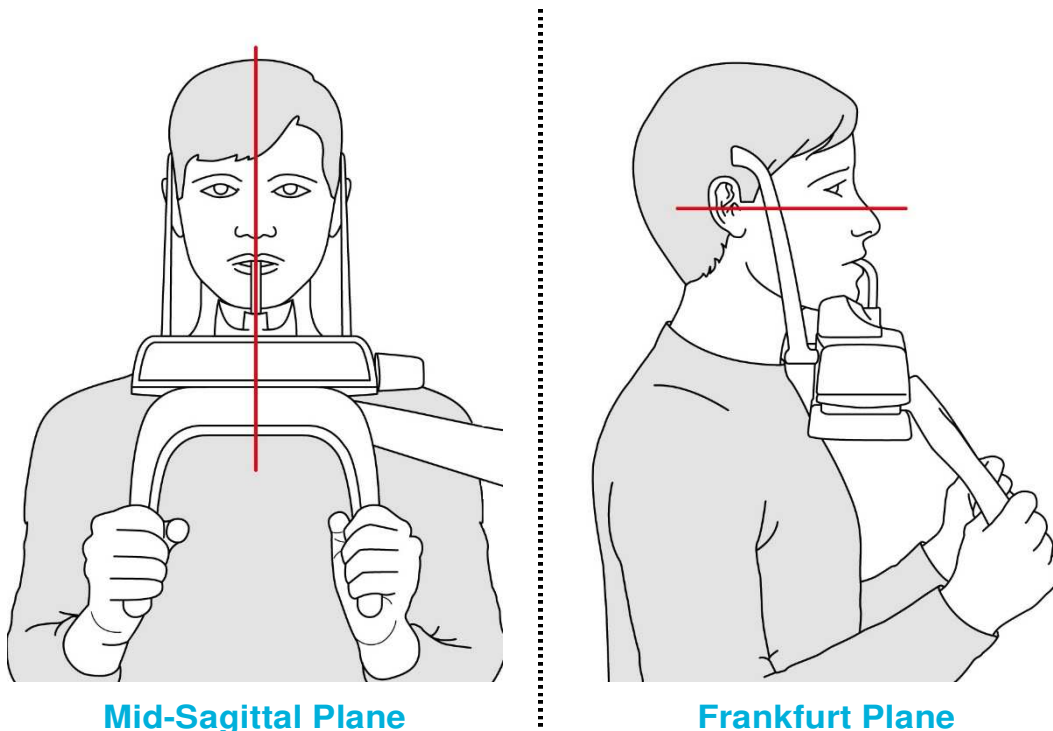

Figure 32

6. Spine should be well stretched, this is normally obtained by asking the patient to step forward, making sure that all other conditions are unchanged. If not properly extended, the spine will cause the appearing of a lower exposed area (clearer) in the front part of the image.

7. Instruct the patient to swallow and keep the tongue against the palate. Patient's tongue must be held closely to the roof of the mouth during the exposure, otherwise a dark air space between the dorsum of the tongue and the palate could obscure the apical region of the maxillary teeth.
8. Patient must stay motionless during the examination.

The result of all the above listed actions will be a radiography where all the parts are properly exposed and are well identifiable as shown in Figure 33.



Figure 33

In a good panoramic image, all anatomic structures are well represented and an equal magnification and sharpness of all structures can be seen.

The image must be symmetric, with the ascending rami of the temporo mandibular joints almost parallel and showing posterior vertical borders. The occlusal plane is quite smiling, despite this the palatal plane does not overlap the apex of the upper arch and therefore allows a good view of the apex itself. The spine is well compensated.



Note

The region of the incisors is the most critical because the anterior portion of the image layer is very narrow. Points 3 and 4 are determining for a good result.



Note

Any flaring of dentition may not allow crowns and apices of both arches to fit in the image layer at the same time. For these patients, you must purposely move him/her further forward in order to move the apices into the image layer.

11.2 Patient positioning errors

11.2.1 Turned head

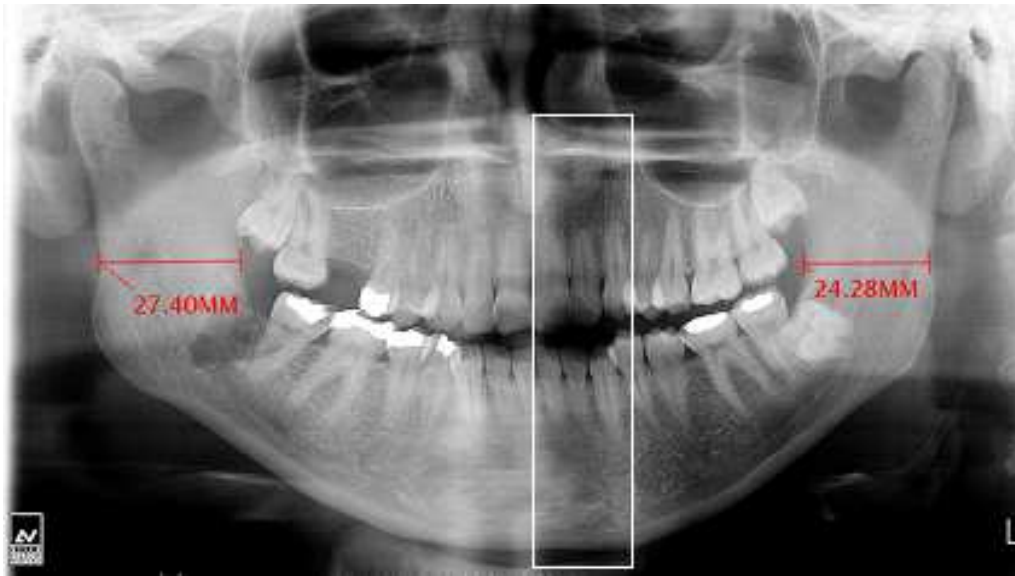
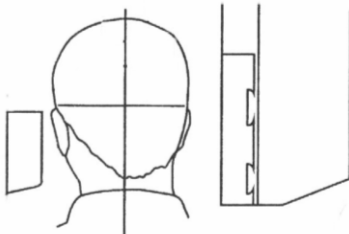

Figure 34



Problem

The patient's head is turned to one side (left or right) in the mid-sagittal plane.

Effects

Condyles are different in size.
The ramous on one side is much wider than the other one.
Asymmetric spine compensation.

11.2.2 Tilted head

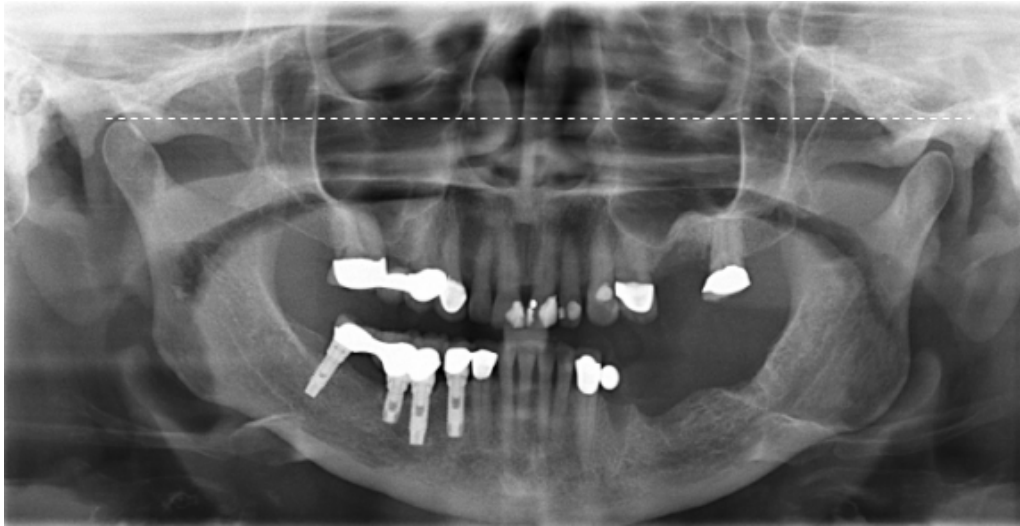
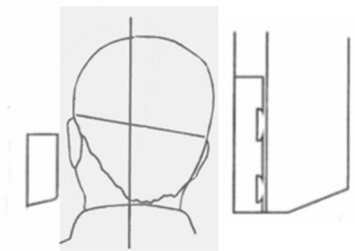

Figure 35



Problem

The patient's head is tilted to one side.

Effects

One condyle appears higher than the other one and the inferior border of the mandible is slanting.

11.2.3 Downward angulation of the head



Figure 36



Problem

The Frankfurt plane is tilted downward.

Effects

The roots of the mandibular anterior teeth are positioned outside the focal trough so it is out-of-focus and blurred.

The shadow of the hyoid bone is typically superimposed on the anterior mandible.

Condyles may be cut off at the top of the radiograph.

Pre-molars are severely overlapped.

Severe curvature of the occlusal plane.

11.2.4 Backward angulation of the head



Figure 37



Problem

The Frankfort plane is tilted backward.

Effects

The roots of the maxillary anterior teeth are positioned outside the focal trough so it is out-of-focus and blurred.
The hard palate is superimposed over the apices of the maxillary teeth.
Both condyles may be off the edges of the image area.
The upper incisors can be blurred.
Flattening of the occlusal plane.

11.2.5 Tongue effect

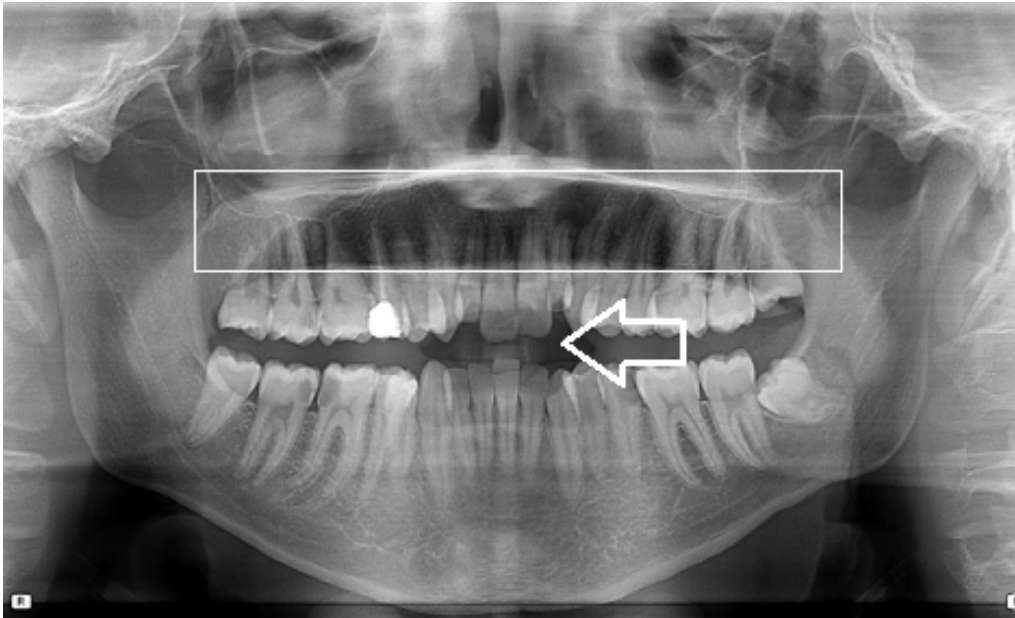
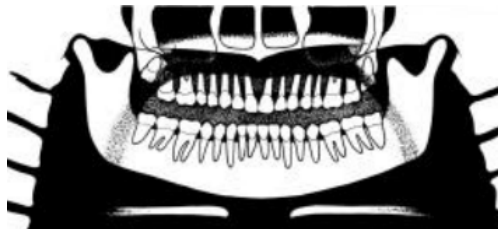

Figure 38



Problem

The patient's tongue was not held closely to the roof of the mouth during the exposure.

Effects

A dark air space between the dorsum of the tongue and the hard and soft palates (palatoglossal air spaces) obscures the apical region of the maxillary teeth.

11.2.6 Spine effect

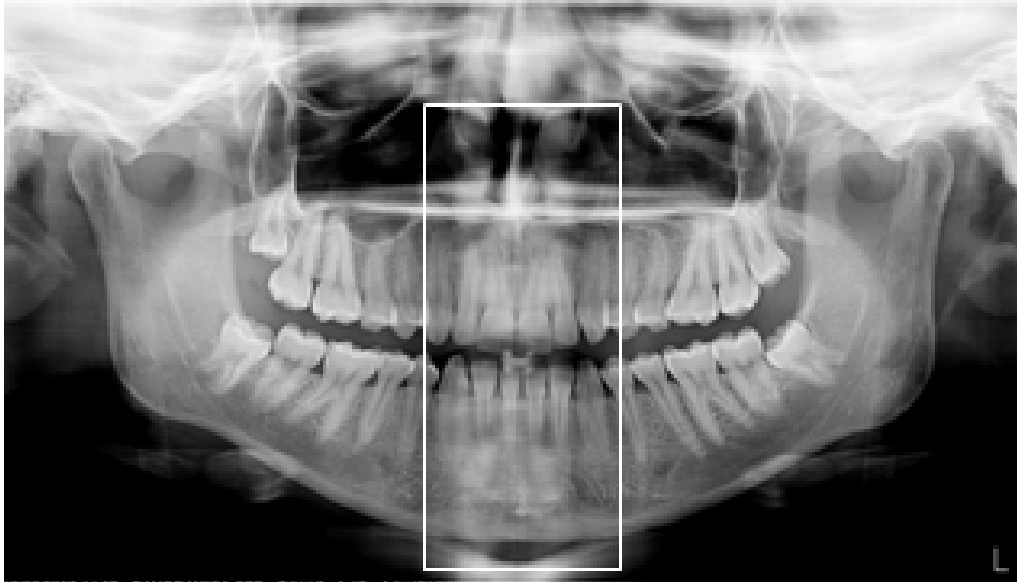
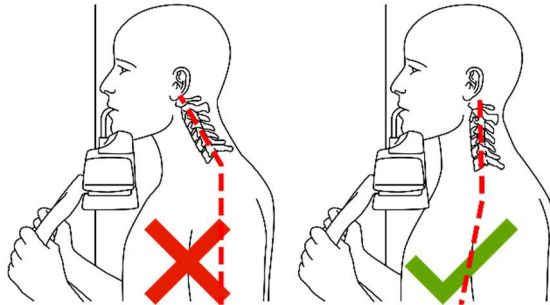

Figure 39



Problem

The patient is slumped.

Effects

The spinal column isn't well stretched causing a ghost image of the spine superimposed in the centre of the image.



MAINTENANCE LOGBOOK

Installation: Date Technician

Maintenance: Date Technician

Cause

Maintenance: Date Technician

Cause

Maintenance: Date Technician

Cause

Maintenance: Date Technician

Cause

Maintenance: Date Technician

Cause

Maintenance: Date Technician

Cause

Maintenance: Date Technician

Cause

CE 0051

de Götzen S.r.l.
Via Roma 45 • 21057 OLGIATE OLONA (VARESE) • ITALY
Tel +39 0331 376 762 • Fax +39 0331 376 763
E-mail: imaging.italysupport@acteongroup.com • www.acteongroup.com

